

TECHNICAL GUIDE

Fiber optic temperature monitoring

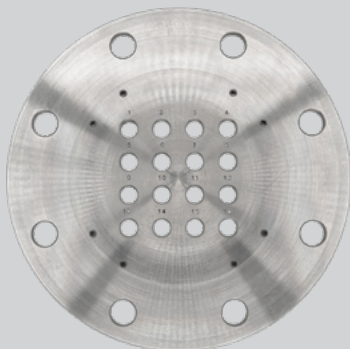
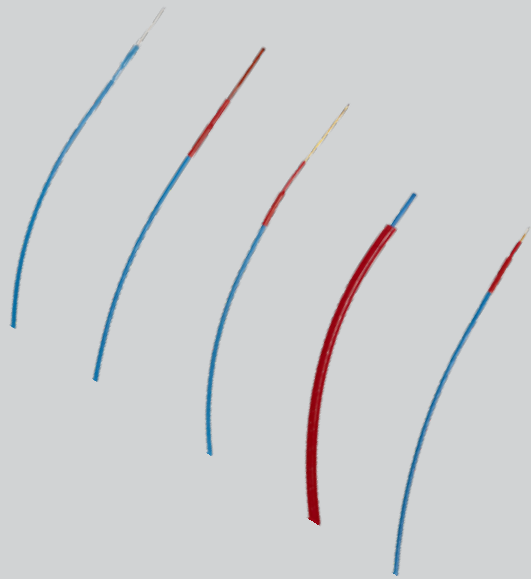

Content index

Fiber optic system overview.....	4
Application	5
Technical data	5
Dimensions.....	9
Order sheet.....	18

Fiber optic temperature monitoring system overview

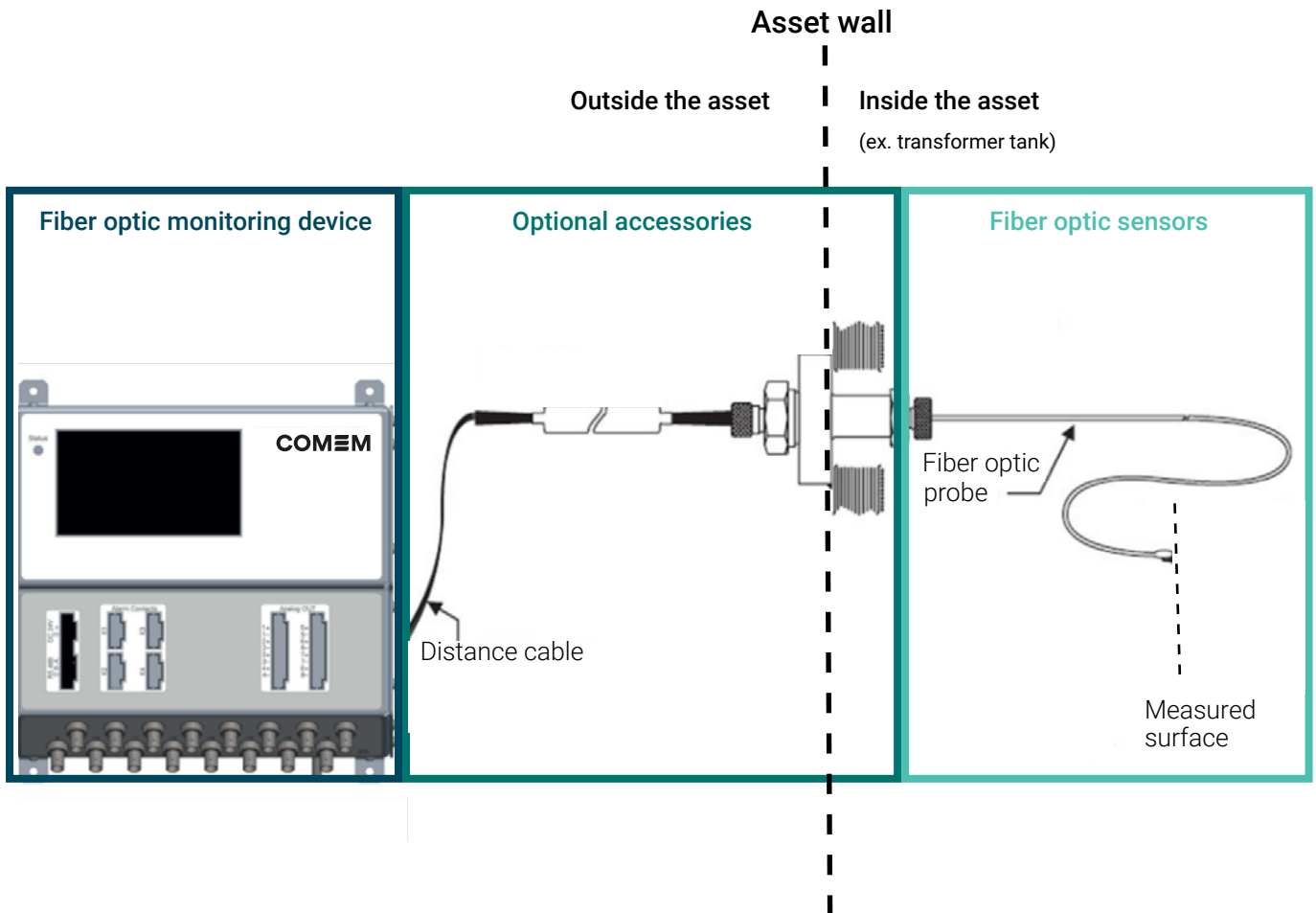

What do you need to build up the right fiber optic system for precise, continuous and direct temperature monitoring?

1. Fiber optic monitoring device suitable for your application
2. Fiber optic sensors
3. Accessories needed for the installation

Application







Applications at a glance

Power & Energy	Biomedical	Harsh & aggressive chemical environments	Process monitoring
Liquid-filled transformers	Catheter	Test laboratories	Fast moving consumer goods (FMCG)
Electric generators	Hyperthermie	University research centers	Industrial food processing
Switchgears & Busbars	MRI, and other magnetic field applications	Industrial applications	Aerospace applications
Nuclear environment	Small Form Factor (SF)	Oil & Gas	Semiconductor & Plasma etching

Applications	Power & Energy	Biomedical	Harsh & aggressive chemical environment	Process monitoring	
Fiber optic devices	FOTEMP MN30	-	●	-	●
	FOTEMP HD20	●	●	●	●
	FOTEMP MS10	-	●	-	●
	FOTEMP C15	●	●	●	●
	FOTEMP C20	-	●	-	●
	FOTEMP T20	●		●	●
	FOTEMP T30	●		●	●





Technical data

Fiber optic monitoring devices

	FOTEMP MN30	FOTEMP HD20	FOTEMP MS10	FOTEMP C15	FOTEMP C20	FOTEMP T20	FOTEMP T30
							
Number of channels	1	1, 2	1, 2, 4 per module	1, 2, 4	1, 2, 4	2 to 16	2 to 16
Modules	NO	NO	10x7TE or 5x14TE	NO	NO	NO	4x up to 4 channel
Measuring range	-200°C to 300°C	-200°C to 300°C	-200°C to 300°C	-200°C to 300°C	-200°C to 300°C	-200°C to 300°C	-200°C to 300°C
Accuracy	± 0.2 K	± 0.2 K	± 0.2 K	± 0.2 K	± 0.2 K	± 1 K	± 1 K
Sample rate channel	250 ms	250 ms	250 ms	250 ms	250 ms	250 ms	250 ms
Display	NO	3.5" LCD	0.96" on 7TE or 1.92" on 14TE OLED	NO	2,8" LCD	4.3" LCD	7" LCD
Analog output	none	none	0 - 10 V or 4-20 mA	0 - 10 V or 4 - 20 mA	0 - 10 V or 4 - 20 mA	0 - 10 V or 4 - 20 mA	0 - 10 V or 4 - 20 mA
Relay	none	none	1 per channel	1 per channel	1 per channel	2 programmable, 1 sensor fault, 1 watchdog	16 free programmable relays
Standard interface	TTL, RS232, RS485, USB	USB, Reference sensor	RS232, RS485, USB	USB (standard), RS485	RS485, USB	RS485, USB, Ethernet	RS485, Ethernet, RS232 (debug)
Available protocols	ASCII, Modbus RTU	ASCII	ASCII	ASCII, Modbus RTU	ASCII, Modbus RTU	ASCII, Modbus RTU	Modbus RTU, Modbus ETH DNP3.0, IEC61850, IEC 60870-104
Data logging	Continuous, and timed logging on microSD	Continuous, and timed temperature logging, spectrum snapshots	NO	NO	NO	Continuous, and time logging on microSD	Continuous, and time logging, 32 GB
Power supply	USB-Powered (Standard) 9-24 VDC	12 VDC	100 - 240 VAC / 50 - 60 Hz	24 VDC	24 VDC	24 VDC	24 VDC
Mounting / Housing options	Mounting holes	none	19" rack mount chassis, 84TE or 42TE CabinetE	DIN rail mounting bracket, Pressed nuts, Threaded bolts	DIN rail mounting bracket, Pressed nuts, Threaded bolts	DIN rail mounting bracket	DIN rail mounting bracket or standard mounting brackets
Connector type	ST	ST	ST	ST	ST	ST	ST

Technical data

Fiber optic sensors

	TS2P	TS3	TS4	TS5	TST
					
Key features	Small form factor with high thermal responsiveness, and local resolution	Customizable probe with high mechanical ruggedness	Customizable probe with chemical resistance	Customizable probe with high adaptability	Probe without air inclusions, designed for transformers
Long-term temperature range	-200°C to +260°C	-200°C to +260°C	-200°C to +260°C	-200°C to +260°C	-200°C to +260°C
Short-term temperature range	+260°C to +300°C	+260°C to +300°C	+260°C to +300°C	+260°C to +300°C	+260°C to +300°C
Accuracy	± 0.2 K	± 0.2 K	± 0.2 K	± 0.2 K	± 0.2 K
Thermal response	20 K/s	12 K/s	7 K/s	19 K/s	3 K/s
Fiber diameter	200µm	200µm	200µm	200µm	200µm
Cable coating	Polyimide / PTFE	Polyimide / PTFE	PTFE	Polyimide / PTFE	PTFE
Connector type	ST	ST	ST	ST	ST
Optional	na	na	na	na	Nomex® J-Spacer Nomex® Disk-Spacer

Service & Calibration

Re-calibration is typically not necessary throughout the entire lifespan of the fiber optic temperature measurement system.

However, if specific needs arise, we offer comprehensive calibration services for our products to ensure accurate temperature measurements.

Our laboratory is equipped with the latest technology and staffed by qualified professionals to guarantee that your device will be highly accurate, returned to specification and put back into service in the shortest time possible.

You will receive your calibrated or serviced devices along with a full compliance certificate and a copy of the test results.

The COMEM devices are also compatible with other 200-micron fibers from different manufacturers.

However, we must recalibrate our device to produce reliable and accurate measurements with a different sensor. Each channel on a device is calibrated to a specific sensor.

For assistance please contact us.

Technical data

Accessories

Feedthrough DF1 - NPT 1/4"



Temperature range	From -40°C to +120°C
Pressure	Max. 200 bar
Thread size	¼" NPT
Thread angle	60°C
Connector type	ST
Probes	Compatible with all COMEM fiber optic sensors

KF40 Flange



Material	Stainless steel
Dimension	Customizable on customer request
Number of feedthroughs	1 or 2
Mounting	Welded
Under-pressure rating	10 ⁴ (-6) Torr
Probes	Compatible with all COMEM fiber optic sensors

Tank Wall Plate & J-Box

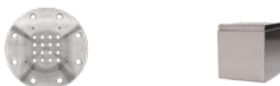

Material	Stainless steel
Number of feedthroughs	1-16
Mounting	Welded or screwed on tank wall
Probes	Compatible with all COMEM fiber optic sensors

J-Spacer & Disk-Spacer; Busbar



Material	Nomex
Dimensions	Customized dimensions available upon request

Feedthrough DF5 - Metric M14



Temperature range	From -40°C to +120°C
Pressure	Max. 2 bar
Thread size	M14 X 1.5
Thread angle	60°C
Connector type	ST
Probes	Compatible with all COMEM fiber optic sensors

Distance cable



Temperature range	From -40°C to +85°C
Fiber Ø	200 µm
Sensor lengths	2 m up to 20 m (PTFE or PVC) (up to 30 m with PVC)
Connector type	ST with metallic ferrule (-40°C to 85°C)
Signal conditioner	Compatible with all COMEM fiber optic sensors

Distance cable - multiwire



Inner material	PVC
	PE
Amount PCF-Elements (200/230)	6
Min. bending radius (short term)	120 mm
Min. bending radius (long term)	100 mm
Max. load (short term)	1200 N
Max. load (long term)	1000 N
Operating temperature	From -40°C to +70°C

Dimensions

Fiber optic devices

FOTEMP MN30

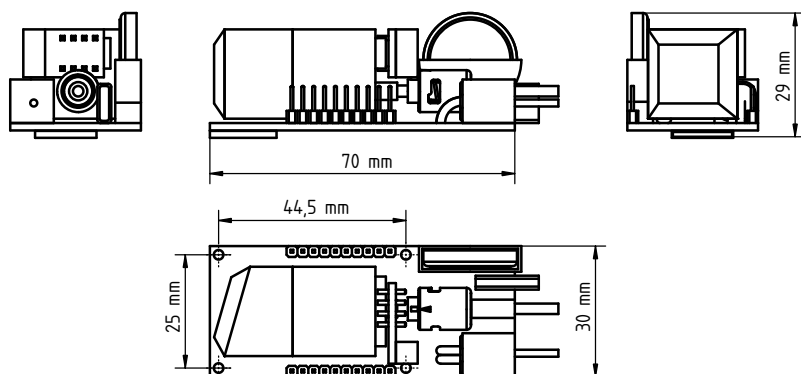

Width (mm)	Height (mm)	Depth (mm)	Weight (Kg)
30	29	70	0.2

FOTEMP HD20

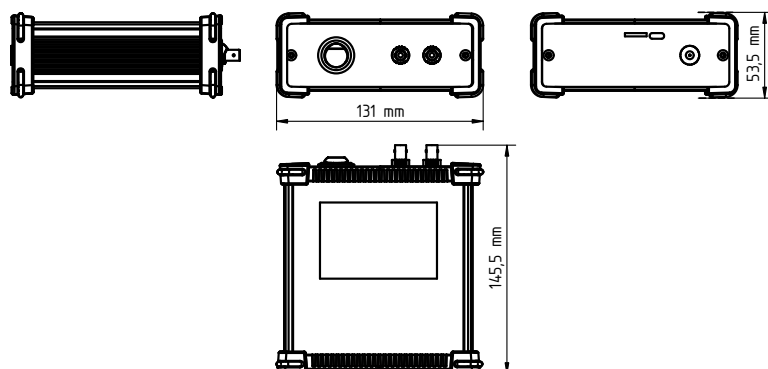

Width (mm)	Height (mm)	Depth (mm)	Weight (Kg)
131	145,5	53,5	0.6

Dimensions

FOTEMP MS10

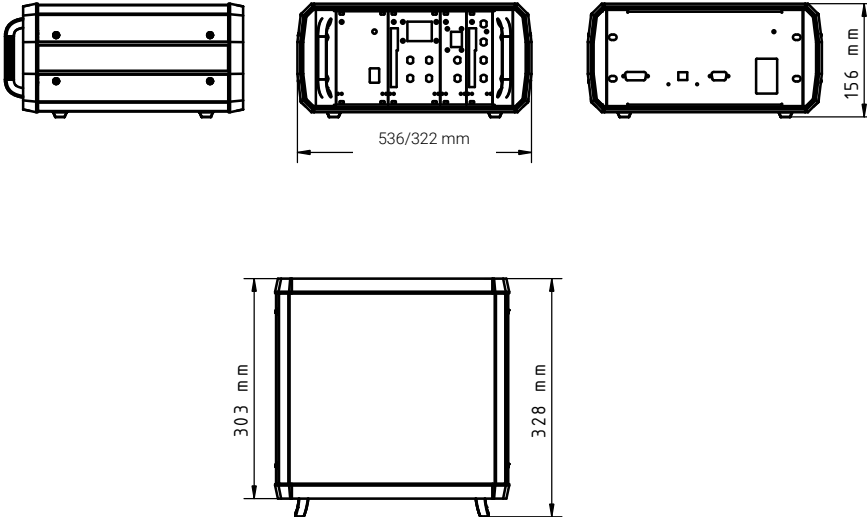

Desktop housing

Version	Width (mm)	Height (mm)	Depth (mm)	Weight (Kg)
84TE	536	156	328	0.2
42TE	322	156	328	0.2

Cabinet mounting

Version	Width (mm)	Height (mm)	Depth (mm)	Weight (Kg)
19" Rack	488	133	247	0.2

FOTEMP C15

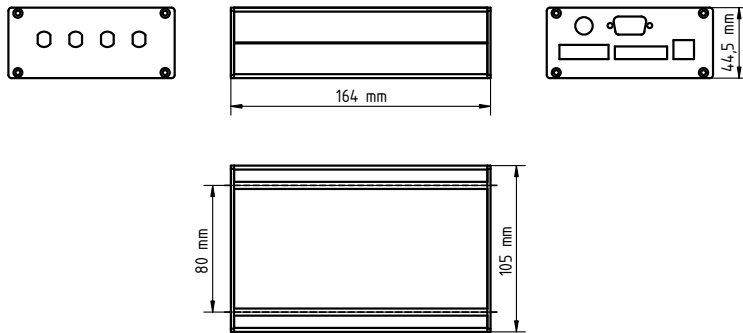

Width (mm)	Height (mm)	Depth (mm)	Weight (Kg)
105	44,5	164	0.5

FOTEMP C20

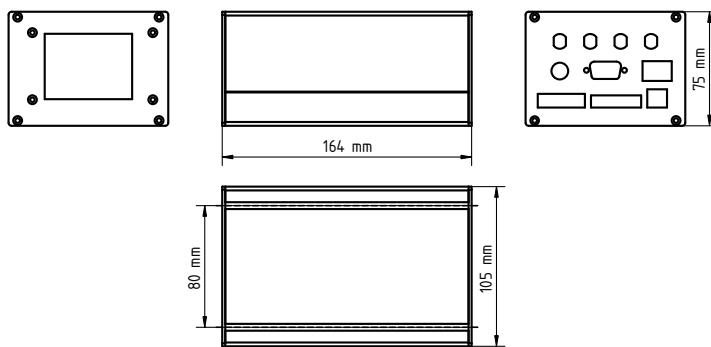

Width (mm)	Height (mm)	Depth (mm)	Weight (Kg)
105	75	164	0.5

Dimensions

FOTEMP T20

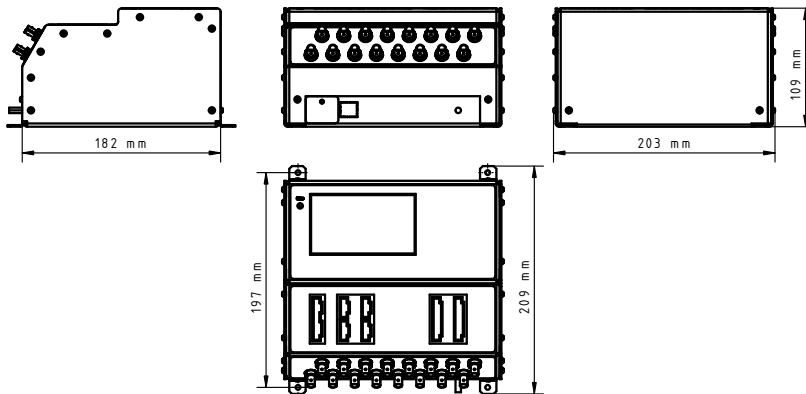

Width (mm)	Height (mm)	Depth (mm)	Weight (Kg)
203	209	109	2.0

FOTEMP T30

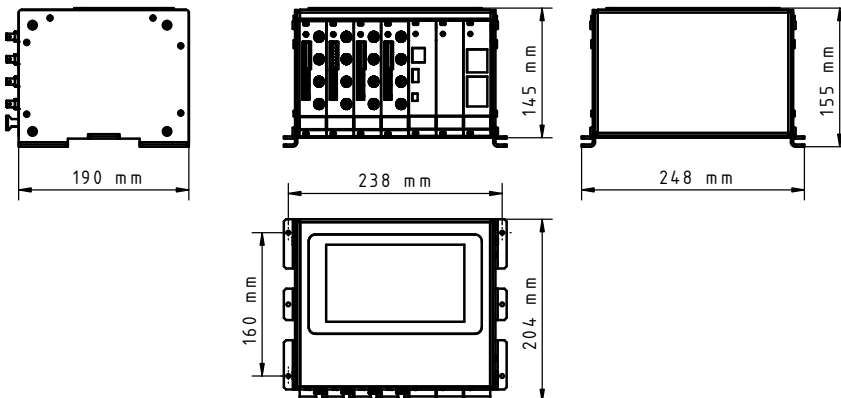

Width (mm)	Height (mm)	Depth (mm)	Weight (Kg)
248	204	155	2.0

TS2P

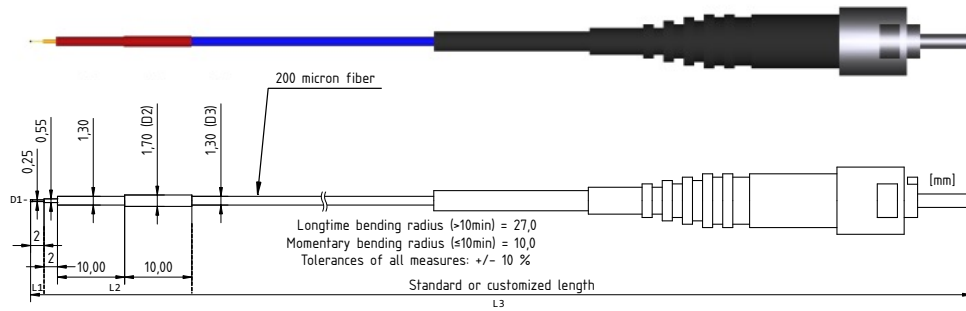
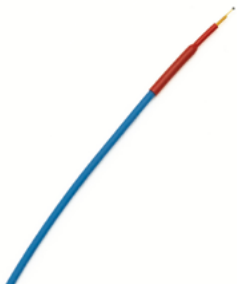

Probe dimensions	D1	0.45 mm
	D2	1.7 mm
	D3	1.3 mm
Dimensions * Other lengths on request	L1	2 mm
	L2	22 mm
	L3	2 - 20 m

* 2m standard, other lengths on customer request up to 20m

TS3

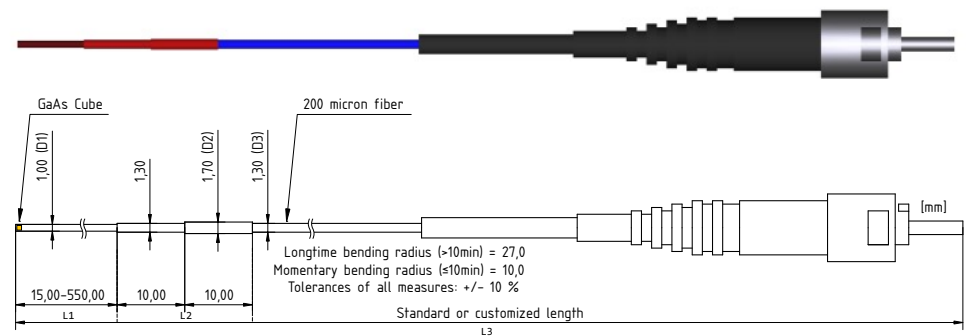

Probe dimensions	D1	1.0 mm
	D2	1.7 mm
	D3	1.3 mm
Dimensions * Other lengths on request	L1	15 - 550 mm
	L2	20 mm
	L3	2 - 20 m

* 2m standard, other lengths on customer request up to 20m

Dimensions

TS4

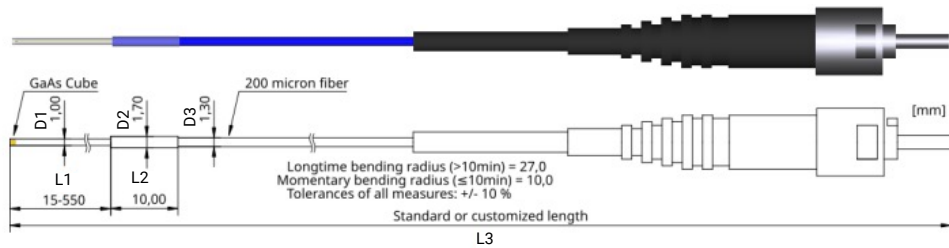

Probe dimensions	D1	1 mm
	D2	1.7 mm
	D3	1.3 mm
Dimensions * Other lenghts on request	L1	15 - 550 mm
	L2	10 mm
	L3	2 - 20 m

* 2m standard, other lenghts on customer request up to 20m

TS5

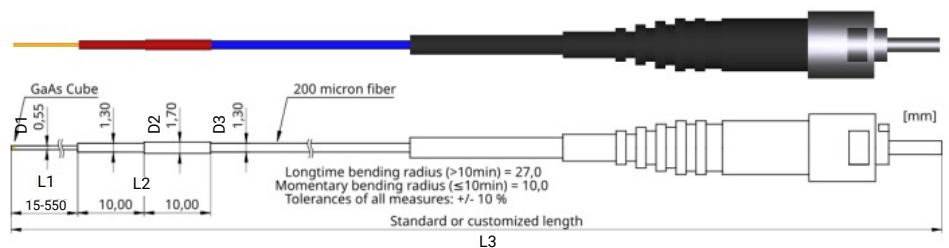

Probe dimensions	D1	0.55 mm
	D2	1.7 mm
	D3	1.3 mm
Dimensions * Other lenghts on request	L1	15 - 550 mm
	L2	20 mm
	L3	2 - 20 m

* 2m standard, other lenghts on customer request up to 20m

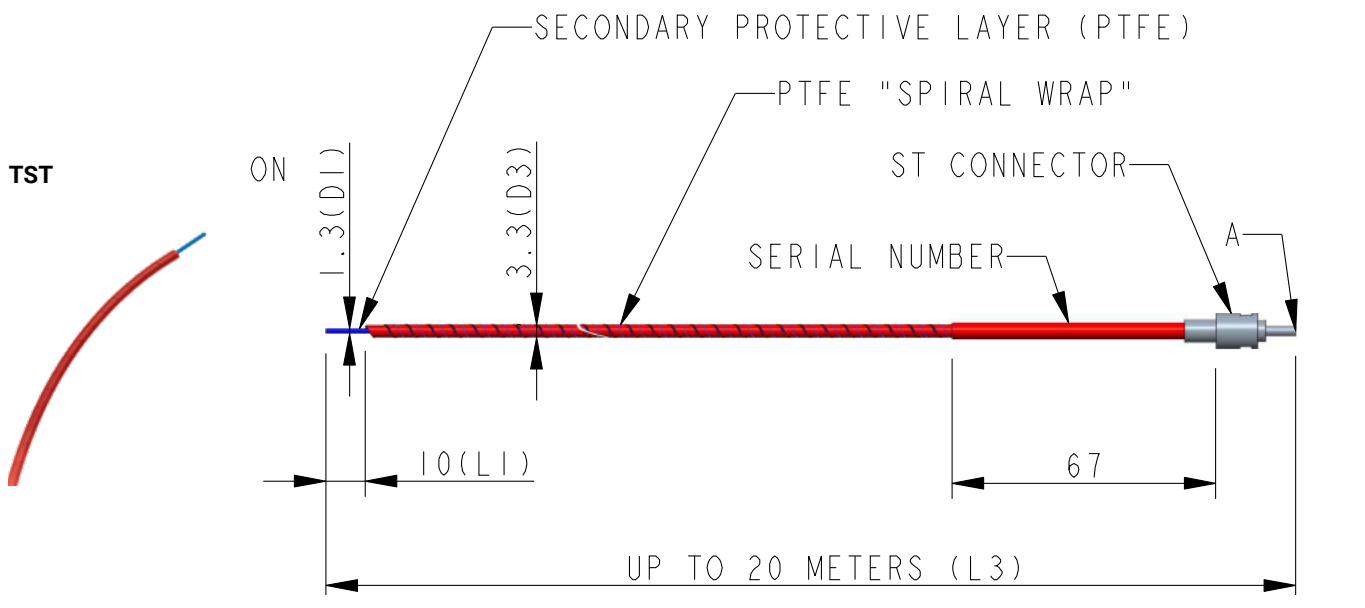

Probe dimensions	D1	1.3 mm
	D3	3.3 mm
Dimensions * Other lengths on request	L1	10 mm
	L3	1 - 12 m

* 3m standard, other lengths on customer request up to 20 m

Dimensions

Accessories

Spacers

J-spacer

(customized dimensions available upon request)

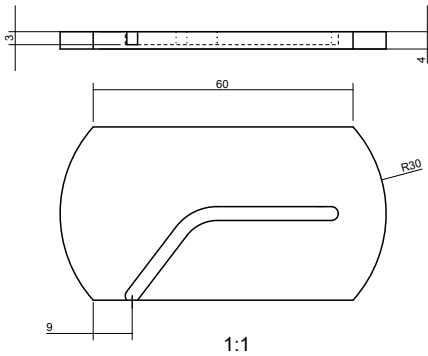

Disk-spacer

(customized dimensions available upon request)

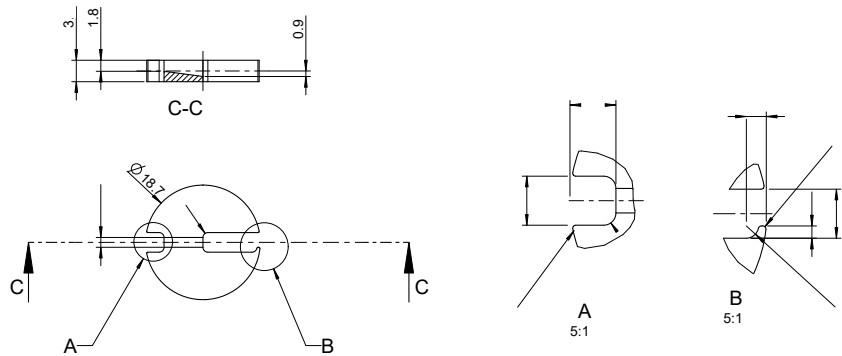

Feedthroughs

Feedthrough DF1-NPT 1/4"

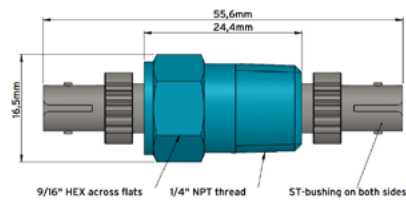

Feedthrough DF5 -METRIC M14

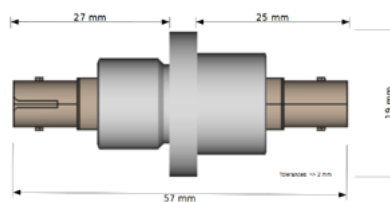

Tank Wall Plate (TWP)

- Preassembled kit
- 24-hour leakage-tested

Tank wall plate	R: 125 mm L: 30 mm
Block flange DN125	R: 125 mm L: 30 mm
J-Box	156x156x164,5 mm

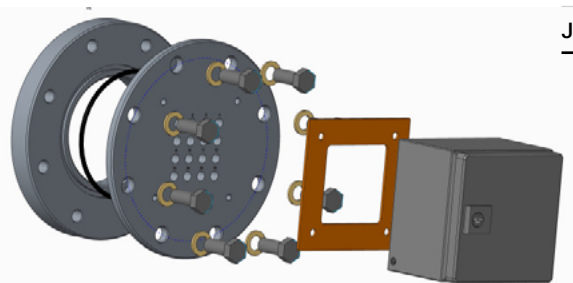

Two models available:

1. TWP 8 (up to 8 feedthroughs)
2. TWP 16 (up to 16 feedthroughs)

Distance cable (optional)



Fiber \varnothing	200 μ m
Sensor standard lengths	2 m up to 20 m (up to 30 m with PVC)

Multiwire distance cable FO - DC6 (optional)



Wire- \varnothing (mm)	3.5 mm
External- \varnothing (mm)	7.5 mm
Min. blending radius (short term)	120 mm
Min. blending radius (long term)	100 mm
Weight	ca. 80 kg/km

KF40 Flange (optional)



Dimension	R: 27,5 mm L: 59,3 mm
-----------	--------------------------

Order sheet

Date	
Rev.	
Customer reference	

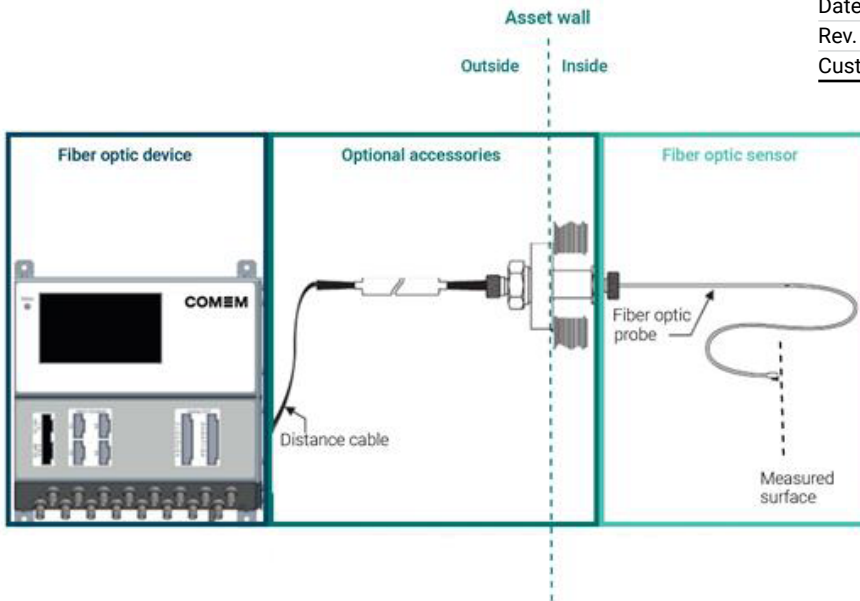

Fiber optic monitoring devices

Application	
Power & Energy	<input type="checkbox"/>
Biomedical	<input type="checkbox"/>
Harsh & aggressive chemical environment	<input type="checkbox"/>
Process monitoring	<input type="checkbox"/>
Other (please specify)	<input type="text"/>

Device type (see page 5 & 6)	
FOTEMP MN30	<input type="checkbox"/>
FOTEMP HD20	<input type="checkbox"/>
FOTEMP MS10	<input type="checkbox"/>
FOTEMP C15	<input type="checkbox"/>
FOTEMP C20	<input type="checkbox"/>
FOTEMP T20	<input type="checkbox"/>
FOTEMP T30	<input type="checkbox"/>

Channels (see page 6)	
1	<input type="checkbox"/>
2	<input type="checkbox"/>
4	<input type="checkbox"/>
6	<input type="checkbox"/>
8	<input type="checkbox"/>
10	<input type="checkbox"/>
12	<input type="checkbox"/>
14	<input type="checkbox"/>
16	<input type="checkbox"/>
More than 16	<input type="checkbox"/>

Temperature calibration	
From -20°C to +150°C	<input type="checkbox"/>
From -40°C to +200°C	<input type="checkbox"/>
From -40°C to +300°C	<input type="checkbox"/>
From -200°C to +300°C	<input type="checkbox"/>
Special request (please specify)	<input type="text"/>

Display for FOTEMP MS10 only (see page 6)	
Yes	<input type="checkbox"/>
No	<input type="checkbox"/>

Housing for FOTEMP MS10 only (see page 6)	
Desktop version 84TE	<input type="checkbox"/>
Desktop version 42TE	<input type="checkbox"/>
Cabinet version 19" Rack mounted	<input type="checkbox"/>

Selectable communication protocols (see page 6)	
Reference sensor (for FOTEMP HD20)	<input type="checkbox"/>
Modbus RTU over IP (for FOTEMP T20)	<input type="checkbox"/>
DNP3 IEC61850 (for FOTEMP T30)	<input type="checkbox"/>

Analog output signal (see page 6)	
None (for FOTEMP C15 C20 T20)	<input type="checkbox"/>
0 - 10 V (for FOTEMP C15 C20 T20)	<input type="checkbox"/>
4 - 20 mA (for FOTEMP T20)	<input type="checkbox"/>
Analog output + Relay (for FOTEMP C15 C20)	<input type="checkbox"/>

Order sheet

Fiber optic sensors

Sensors (see page 7)	Quantity	
TS2P		
TS3		
TS4		
TS5		
TST		

Sensor lengths	
2 m (Standard)	
Other lengths from 3 up to 20 m (upon request)	

Tip length (TS3, TS4, TS5)	
15 - 20 - 30 - 40 .. up to 550 mm	

Accessories

Spacers	Quantity	
J-Spacer (Nomex)(for TST sensor)		
J-Spacer (Peek) (for TST sensor)		
Disk-Spacer (Nomex) (for TST sensor)		
Busbar for radial mounting (Peek) (for TS3 sensor)		

Feedthroughs	Quantity	
Feedthrough DF-1-NPT 1/4"		
Feedthrough DF5 - metric M14		

TWP set for Transformer applications	Quantity	
TWP 8 (1 - 8 feedthroughs)		
TWP 16 (9 - 16 Feedthroughs)		
DN125		
J-Box		

Distance cables	Length	Quantity
PTFE coating (2 m)*		
PVC coating (2 m)**		
Spiral wrap with PTFE coating (2 m)**		
Multiwire distance cable F0-DC6 (2 m)**		

Note: * Length from 3 m upto 20 m is available upon request.
 ** Length from 3 m upto 30 m is available upon request.

Flanges	Quantity	
KF40 (1 channel)		
KF40 (2 channels)		

COMEM SpA

Localita' Signolo 22, S.R.11
36054 Montebello Vicentino
Vicenza - Italy
Tel +39 0444 449 311

COMEM Optocon GmbH

Washingtonstraße 16/16a
D-01139 Dresden
Germany
Tel +49 (0)351 8435990

www.comem.com

The data and illustrations are not binding. We reserve the right to modify the contents of this document without prior notice following the technical and product developments.

Copyright 2026 COMEM. All rights reserved

Technical guide-04-2026