

INSTRUCTION MANUAL

# FOTEMP T30

Fiber optic temperature measurement



# Content index

Introduction .....	3
Safety information .....	3
Product description .....	5
Installation .....	8
Automatic Integration Time Adjustment ...	10
Software operation .....	10
Maintenance .....	20
Troubleshooting .....	21
Disposal .....	21
Communication protocols .....	22
Technical data .....	30
Terms and abbreviations .....	31

# Introduction

Thank you for purchasing FOTEMP T30 temperature measurement device. In combination with the TS temperature sensors, FOTEMP T30 offers reliable and proven online temperature monitoring.

For safe and proper use, carefully read the user manual and all accompanying documentation and keep instructions for further reference.











## CE conformity

FOTEMP T30 fulfills the legal requirements of the applicable EC guidelines. By attaching the CE mark, COMEM provides confirmation of successful testing. CE conformity declaration can be shared, please contact COMEM.

The device conforms to the following European directives:

- EN 61326-1:2013 (EN 55011)
- EN 60255-26:2013 + AC:2013
- EN 60068-2-14:2009
- EN 60068-2-30:2005
- RoHS2011/65/EU

## Conventions used in this manual

Symbols and formatting	Definition
	Refer to instruction manual
	Important information, tips or note
	Authorized personnel: electrician
	Authorized personnel: technician
	Authorized personnel: operator
	Authorized personnel: COMEM service
	Prerequisites, needed materials and tools
	Arrows to move back and forth between screens and settings
	Drop down arrow to select between more options
<i>Italic</i>	Items, options and buttons on the software interface
	Arrows to select numbers, signs and units

Symbols and formatting	Definition
(Figure 3, item 8)	Cross reference to figure The first number refers to the figure number, the second to the item in the figure.
1. ... 2. ...	Instruction consisting of more steps
◆ ...	Instruction consisting of one step
	Result or outcome of an action
•	List entry

## Accompanying documentation for accessories

The following accompanying documentation is also relevant to using the FOTEMP T30 in addition to this user manual:

- Cleaning tool instruction manual (provided together with the cleaning tool)
- Handling instruction for fiber optic cables and sensors (provided together with the cable or sensor)
- Power supply instructions (provided together with power supply)
- Instructions about installation of measurement modules (provided together with the measurement module)

## Warranty

Products supplied by the COMEM are warranted against defects in material and workmanship for a period of five years for FOTEMP T30 following shipment. Our liability is specifically limited to replacing or repairing the defective device. Equipment returned to the factory for repair must be shipped prepaid and insured. This warranty does not include batteries, lamps, or other expendable items, where the original manufacturer's warranty shall apply. COMEM makes no other warranty. The warranty is void in the event of abuse, e.g. failure to follow recommended operation procedures or failure by the customer to perform as specified in the instruction manual.



# Safety information

## Explanation of safety warnings

Used signal words:

- **DANGER** indicates a hazardous situation which, if not avoided, will result in death or serious injury.
- **WARNING** indicates a hazardous situation which, if not avoided, could result in death or serious injury.
- **CAUTION** indicates a hazardous situation which, if not avoided, could result in minor or moderate injury.
- **NOTICE** indicates a hazardous situation which, if not avoided, could result in damage to the device or other property.

Used warning symbols:

-  Electrical hazard
-  General hazard

The warning messages are displayed as follows:



	<b>DANGER</b>
<p><b>Hazardous situation</b>                  Will result in serious injury or death!                  → Measures to avoid the situation.</p>	



	<b>WARNING</b>
<p><b>Hazardous situation</b>                  Could result in serious injury or death!                  → Measures to avoid the situation.</p>	

	<b>CAUTION</b>
<p><b>Hazardous situation</b>                  Could result in minor or moderate injury!                  → Measures to avoid the situation.</p>	

	<b>NOTICE</b>
<p><b>Hazardous situation</b>                  Could result in property damage!                  → Measures to avoid the situation.</p>	

**Specific safety information**

	<b>WARNING</b>
	<p><b>Electric voltage</b>                  Death or serious injury due to electric voltage!                  → Ensure that the supply voltage matches the specifications of the product.                  → Secure all connections carefully.                  → Disconnect any power supply before installation/disassembly.                  → Ensure that no voltage is present.                  → Secure against switching on again.                  → Check all equipment carefully for damage: use only flawless parts.                  → Do not open the device.                  → Do not make changes to or perform repairs on the device, on its components or its accessories.                  → Keep the device away from water and wet surroundings.</p>

	<b>WARNING</b>
	<p><b>Unqualified personnel</b>                  Death or serious injury due to inadequately qualified personnel!                  Damage to the device due to improper handling!                  → Ensure that only properly qualified personnel perform work on the device.                  → Keep unqualified personnel away from the device.                  → Protect the device against damage during transport, storage and operation.</p>

	<b>NOTICE</b>
<p><b>Moisture and contamination intrusion</b>                  Damage to the device due to penetrating moisture and dirt!                  → Protect the device against humidity and dirt.                  → Only operate the device in a clean and dry environment.                  → For outdoor applications use a weatherproof enclosure or housing.</p>	

	<b>NOTICE</b>
<p><b>Hard and sharp objects on touch screen</b>                  Damage to the touch screen due to contact with hard and sharp objects!                  → Only operate the touch screen with your fingers.                  → Protect the touch screen from contact with hard objects.</p>	

	<b>NOTICE</b>
<p><b>Full or damaged internal storage</b>                  Loss of recorded data due to full or damaged internal storage!                  → Download and backup recorded data regularly.                  → Check storage status and usage periodically.</p>	

	<b>NOTICE</b>
<p><b>Contamination on fiber optic connectors</b>                  Damage to the fiber optic connections due to dust, particles, residues of cleaning agents and grease!                  False signal or loss of signal due to contamination on the fiber optic connectors!                  → Do not remove the protective rubber caps from the fiberoptic connectors.                  → Remove the protective rubber caps only before connecting a cable.                  → Clean fiberoptic plug and socket using the provided cleaning tool before connecting the cable.                  → Keep covers in case of sensor disassembling.</p>	

	<b>NOTICE</b>
<p><b>External light sources</b>                  False signal or loss of signal due to exposure of fiber optic connectors to external light sources!                  → Avoid exposure of optic connectors to external light sources.                  → Remove the protective rubber caps only before connecting a cable.</p>	

**Intended use and reasonably foreseeable misuse**

The FOTEMP T30 is a fiber optic temperature measurement device. Together with the COMEM fiber optic temperature sensors, the FOTEMP T30 can be applied for temperature monitoring. Correct function can only be guaranteed in combination with temperature sensors of the TS series from COMEM. COMEM assumes no responsibility nor liability for accidents, damage and malfunctions resulting from the use of sensors from other manufacturers.

FOTEMP T30 sensors are intended to be used for temperature measurement within the technical specifications in the following application areas:

- Microwave
- High frequency
- High voltage
- Magnetic or aggressive environments where metallic temperature sensors are either inaccurate or hazardous.

FOTEMP T30 is not intended to be used for the following purposes:

- Use in potentially explosive areas
- Use after technical changes or modifications to the device not expressly approved by COMEM
- Use with nonapproved or inadequate replacement or accessory parts
- Any other type of use and operation beyond the limits of technical specifications.

**Target groups and qualification of personnel**

At the beginning of each chapter or task in this manual, the authorized personnel are listed. Only personnel with the qualifications described are allowed to carry out work on the temperature measurement device. All personnel assigned to work with FOTEMP T30 must have read and understood the manual and follow the instructions provided.

Personnel	Description
Electrician	Due to technical education, knowledge and experience, as well as knowledge of applicable standards and regulations, an authorized electrician can carry out work on electrical equipment and independently detecting and avoiding possible dangers. The electrician is specially trained for the operational site where he or she works and knows the relevant standards and regulations. He or she must be able to provide evidence of experience with the electrical and mechanical installation of similar devices. He or she possesses general mechanical ability which includes skills in the use of electrical and mechanical equipment, ability to interpret wiring diagrams, blueprints, and schematics.
Technician	Due to technical education, knowledge and experience, as well as knowledge of applicable standards and regulations, a technician can carry out tasks assigned to him and of independently detecting and avoiding possible dangers. The technician must have in depth knowledge of the specific application. He must be able to provide evidence of training or multiple years of experience working in the field or industry of the application. The technician must also be able to provide evidence of knowledge in computer sciences, especially in networking and communication protocols.

Personnel	Description
Operator	The operator must have knowledge about the specific application and the device. Additionally, the operator is trained in temperature and device monitoring. He or she can verify and control the status of the device and independently recognizes any possible error or alarm that is preventing normal operation.
COMEM service personnel	Certain tasks may only be carried out by COMEM service personnel. These tasks include repair work, firmware and software update, battery replacement and calibration. Other individuals are not authorized to carry out these specific tasks. To have this work carried out, contact the COMEM service technician assigned to you.

## Product description

**Unpacking and inspection**

To unpack and inspect your FOTEMP T30 Temperature measurement device perform the following steps:

1. Carefully unpack all components.
2. Store the packing material until you have inspected all components.
3. Check if you received all items listed on the enclosed packing list.
4. Inspect the items for damage.
5. If you note any damage or suspect damage, immediately contact COMEM.

**Scope of delivery**

Together with the FOTEMP T30, the following accessories are provided:

- One cleaning tool for fiber optic connectors.
- Protective rubber caps for all fiber optic connectors.
- Suitable electrical plugs for all the supply modules and measurement module sockets.

Additional accessories are optional. Handling and operation of optional accessories are not described in this manual.



### NOTICE

Depending on the chosen options in order, your product may differ from the images shown in this manual.

This manual presumes a fully equipped device with 4 modules and 16 fiber optic connector sockets. Therefore, the images show 16 connected temperature sensors and available analog outputs and relays.

**Product overview**

**Functionality**

- Main product features
- Temperature measurement on gallium-arsenide based sensors
- Choice of 2 to 16 measurement channels
- 7" TFT display with touchscreen
- Data recording in internal memory
- Software function allowing logic definition for channel to relay allocation
- Configurable with one analog output per channel
- System watchdog function
- Modbus (optional: DNP3, IEC61850, IEC60870-5 communication protocols)
- Complete immunity of fiber optic sensors to RFI, EMI, NMR and microwave radiation
- Built-in uninterruptible power supply (UPS) up to 5 min

**Front panel**

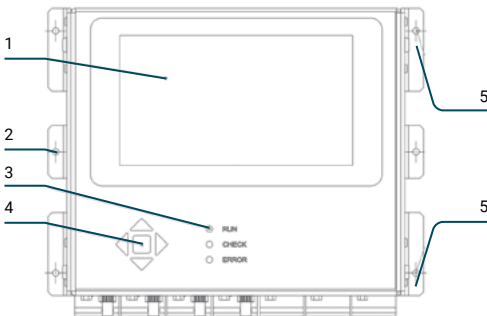

Figure 1: FOTEMP T30 front panel

- 1 7" TFT touch screen display
- 2 DIN rail mounting points (one on each side)
- 3 Status LEDs of controller
- 4 Keypad
- 5 Back panel mounting points (two on each side)

**Keypad**

Key	Function
	Select an item or an input field on the display.
	Select an item or an input field on the display.
	Confirm a selection.
	Enter letters and numbers
	Enter letters and numbers

**Status LEDs**

Status	Description
<span style="color: green;">●</span> RUN	Normal operation.
<span style="color: yellow;">●</span> CHECK	Limited operation. Action may be required.
<span style="color: red;">●</span> ERROR	Malfunction of device. Action required.

To learn more about the required actions, see chapter 7 Troubleshooting.

**Connections**

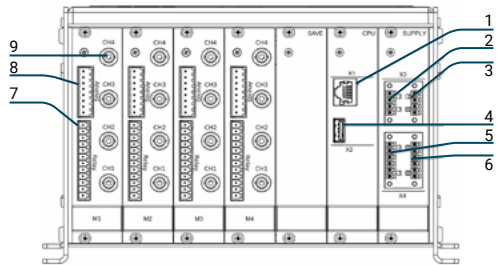

Figure 2: FOTEMP T30 connections

- 1 Ethernet socket (X1)
- 2 Serial port RS232 socket and plug (X3)
- 3 Serial port RS485 (half duplex) socket and plug (X3)
- 4 USB socket (X2)
- 5 Power supply socket and plug (X4)
- 6 Serial port RS485 (full duplex) socket and plug (X4)
- 7 Relay sockets and plug (3 plugs with 4 pins each)
- 8 Analog output socket and plug
- 9 Fiber optic connector socket (maximum 16)

**Pin layout**

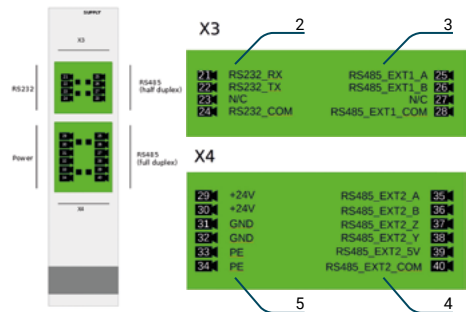

Figure 3: FOTEMP T30 pin layout of supply module sockets

- 1 Supply module
- 2 X3: RS232
- 3 X3: RS485 half-duplex
- 4 X4: RS485 full-duplex
- 5 X4: Power supply

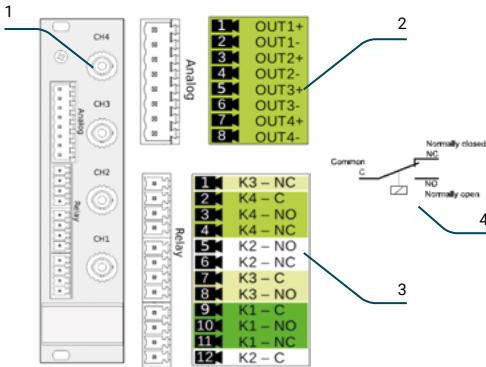

Figure 4: FOTEMP T30 pin layout and relay configuration of measurement module sockets

1	Measurement module
2	Pin layout of analog outputs
3	Pin layout of relays
4	Relay configuration

**Dimensions**

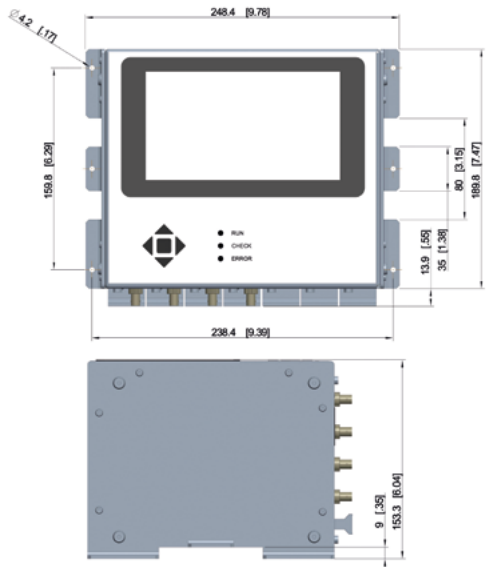

Figure 5: FOTEMP T30 product dimensions in mm and [inch] (front and side view)

**Accessories and spare parts**

Category	Accessories
Temperature sensors	TS2 Comprehensive
	TS3 Flexible
	TS4 Durable
	TS5 Medical
	Custom sensor
	TST Trafo
Other accessories	Bus bar adapter for sensors
	Smart spacer
	Spiral Wrap
	Silicon protective wrap
	Metal protective wrap
	Optical feedthrough
	Tank wall plate
	Tank wall plate cover
	Extension cable
	Cleaning tool
	Power supply
	Measurement modules
	DIN rail mounting clips
RS-232 USB converter	
RS-232 cable	

For more information about the accessories, check our website or contact the COMEM sales and support team. <https://www.comem.com>

# Installation

## Installation site

Requirements of the installation site:

- For outdoor operations a weatherproof enclosure or housing is required.
- Permissible ambient temperature: -20 °C to 70 °C.
- Humidity: maximum 95 % relative air humidity, non-condensing.
- Prevent dust and other contamination from entering the device.
- Avoid direct exposure to sunlight.
- Avoid explosive atmosphere.

## Mounting



Electrician



## NOTICE

### Dropping or falling of device

Damage to the device due to incorrect mounting!

Damage to the device due to falling or dropping!

- Choose a stable support to mount the device.
- Make sure the support can handle the weight of the device.
- Make sure the mounting site can support the weight of the device.
- Do not place the device on an unstable cart, stand, table or shelf.



The scope of delivery does not include mounting materials (e.g. screws, wall plugs, rubber feet or DIN rail mounting kit).

For permanent installation, use the mounting options on the back panel of the device.

To use the DIN rail mounting option, request suitable mounting clips from COMEM.



- Fastening material according to the chosen mounting option.
- Screws with maximal shaft diameter of 4 mm.

To mount FOTEMP T30 using the mounting options on the back panel:

1. Choose a safe and stable place where to mount the device.
  2. Mark the location for the fastening screws.
  3. Prepare the fastening place according to the fastening material (e.g. drill hole, insert wall plugs).
  4. Fasten the device.
- ↳ FOTEMP T30 is mounted to stable support.

To mount FOTEMP T30 using the DIN rail mounting option:

1. Fasten the DIN rail mounting clips to the DIN rail mounting points using suitable screws or pop rivets.
  2. Locate the approximate mounting location on the DIN rail.
  3. Fix the FOTEMP T30 onto the DIN rail using the snap mechanism of the clips.
- ↳ FOTEMP T30 is mounted to the DIN rail.

## Wiring of electrical plugs



Electrician



## NOTICE

### Reverse polarity

No function due to reverse polarity!

- Be careful when wiring the plugs.
- Make sure to connect the wires according to the provided schemas.
- Check for correct polarity before connecting.



## NOTICE

### Interchange of plugs

Damage to the device due to insertion of plug into wrong socket!

- Make sure to connect the plug with the corresponding socket.



## NOTICE

### Excessive torque

Damage to the threads due to excessive torque!

- Tighten the screws with the specified torque range (max. 0.34 Nm).
- Use suitable screwdrivers.



## NOTICE

### Wrong wire cross-section

Damage to the plug!

Breaking of wire inside the plug!

Thermal damage to the wire!

- Use only wires with specified cross-sections (1.31 – 0.129 mm<sup>2</sup>, AWG 16 – 26 for solid and standard wires).



- Terminal-screwdriver dimension 3 mm (3/32") (for analog output plug) and dimension 2.5 mm (1/8") (for all other plugs).
- Acceptable wire size (1.31 – 0.129 mm<sup>2</sup>, AWG 16 - 26 for solid and standard wires).
- Pin layout (Figure 3, Figure 4)

## Power supply plug

To wire the power supply plug:

1. Unscrew the power supply plug.
  2. Remove the power supply plug from the socket (Figure 2, item 5).
  3. Install the wires according to configuration X4 (Figure 3, item 5).
  4. Check polarity and voltage level.
  5. Reinsert the power supply plug into the device.
  6. Tighten the plug fixation screws.
- ↳ Power supply plug is wired.

### Serial port plugs



## NOTICE

**Overload on pin 39**  
 Malfunction of the device!  
 Damage to the device due to overload on the 5V output!  
 → Do not apply more than 250 mA to the 5V voltage output (X4 pin 39, Figure 3, item 4)

To wire the plugs of the serial ports:

1. Unscrew the serial port plugs.
  2. Remove the serial port plugs from the socket (Figure 2, items 6, 8 and 9).
  3. Install wires according to configuration X3 and X4 (Figure 3, items 2, 3 and 4)
  4. Check the wiring.
  5. Reinsert the plugs into the device.
  6. Tighten the plug fixation screws.
- ↳ Serial port plugs are wired.

### Relay plug (optional accessory)

To wire the relay plugs perform the following steps:

1. Remove relay plug(s), (Figure 2, item 4).
  2. Install wires according to configuration (Figure 4, item 3).
  3. Check wiring.
  4. Reinsert plug into device.
- ↳ Relays are wired.



To test the relay configuration, see chapter 5.5.4 Test the relay configuration.

### Analog output plug (optional accessory)



## NOTICE

**Voltage between the OUTx- pins**  
 Damage to the device due to short circuit!  
 → Do not apply voltage potential between the OUTx- pins (Figure 4, item 2). They are connected internally.

To wire the analog output plugs:

1. Remove analog output plug(s), (Figure 2, item 3).
  2. Install wires according to configuration (Figure 4, item 2).
  3. Check wiring.
  4. Reinsert plug into device.
- ↳ Analog outputs are wired.

### Finalize the electrical setup

To finalize the electrical setup, perform the following steps:

1. Check the electrical wiring (Figure 3, Figure 4).
  2. Check and/or tighten all screws also for unused pins to avoid dropping out due to vibration.
  3. Turn on the power supply.
- ↳ Device starts booting.

### Connect a fiber optic cable





## NOTICE

**Breaking fiber optic cables**  
 Damage to the fiber optic cables due to inappropriate handling!  
 False or no signal due to damaged fiber optic cables!  
 → Avoid stretching, bending and pinching of fiber optic cables.  
 → Do not apply excessive force when handling fiberoptic components.



For more information about correct handling of fiber optic cables, refer to the handling instructions for fiber optic cables and sensors (provided together with the cable or sensor).



- Cleaning tool for fiber optic connectors.

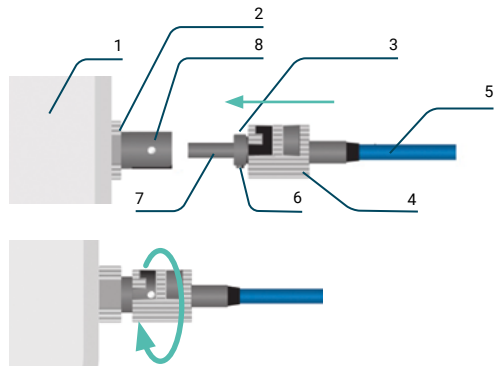

Figure 6: Connecting a fiber optic cable to FOTEMP T30

1	FOTEMP T30
2	Fiber optic connector socket (ST-socket)
3	Locking nut
4	Fiber optic connector plug (ST-plug)
5	Fiber optic cable
6	Connector key
7	Connector tip
8	Socket slot

To connect a fiber optic cable:

1. Remove the protection caps from fiber optic socket and connector tip.
  2. Clean connector tip and socket using a suitable cleaning tool for fiber optic connectors.
  3. Align the connector key with the socket slot.
  4. Gently insert the connector tip into the socket until they are fully mated.
  5. Twist the bayonet lock (bottom).
- ↳ The fiber optic cable is connected to the device.

Dismantling



Electrician

## WARNING

**Electric voltage**  
 Death or serious injury due to electric voltage!  
 → Be aware that attached devices which are controlled by the relays can show unexpected operation.  
 → Ensure that the attached devices are secured.  
 → Ensure disconnection from other power supplies, e.g. relays, analog outputs and serial ports.

- To dismantle FOTEMP T30, perform the following steps:
1. Optional: download the recorded data from your device.
  2. Power off the device.
  3. Disconnect the electrical plugs.
  4. Disconnect the fiber optic connectors.
  5. Reinsert the protection caps on the fiber optic sockets and connector cable tips.
  6. Remove the device from the mounting support.
- 🔗 The device is dismantled.

## Automatic Integration Time Adjustment

Due to factors such as excessive bending/looping of the fiber or mechanical damage, the light signal received by the measuring device may be reduced (below 50%), which is usually a limiting factor for measuring devices. However, to ensure accurate measurements even with high attenuation, FOTEMP devices are equipped with a special function that automatically maintains a high signal strength.

With the “Automatic Integration Time Adjustment” function, highly attenuated signals can be optimized and maintained within a range of 35% to 100% and continue to be used for temperature measurement. Signal levels can be monitored via the FOTEMP Assistant software or, for devices with an integrated display, are shown directly on the user interface.

If the signal strength falls below 35%, an error is displayed in the FOTEMP Assistant software or on the device display (if available). In this case, the sensor or device must be checked for troubleshooting. Please refer to document AN206\_FOTEMP\_Device\_Troubleshooting for more information.

# Software operation

## Software overview

### Main screens

- The software is divided into six main screens. To have access to the following screens, admin rights are required:
- Channel Config
  - Relay Config
  - Monitoring
  - Settings

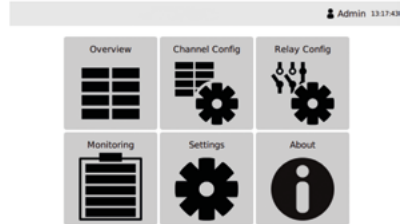

Figure 7: Software main screens

Symbol	Description
	This screen provides an overview of the current temperatures and relay positions.
	Use the Channel Config screen to configure various channel parameters: <ul style="list-style-type: none"> <li>• Description</li> <li>• Temperature offset</li> <li>• Temperature alarm</li> <li>• Analog output</li> <li>• Enable/Disable channel</li> </ul>
	Use the Relay Config screen to set, invert, and test the relay configurations.
	Use the Monitoring screen to set the parameters for the temperature monitoring and download or clear recorded data.
	In this screen you can modify general settings: <ul style="list-style-type: none"> <li>• Language and temperature unit</li> <li>• Display timeout and brightness</li> <li>• Network configuration</li> <li>• Description of the device</li> <li>• Set Time &amp; Date</li> <li>• Import/export device configuration</li> <li>• View/reset watchdog status</li> <li>• Configure communication parameters</li> </ul>
	In the About screen, you can find the serial number of your device and information about the manufacturer.

User interface elements

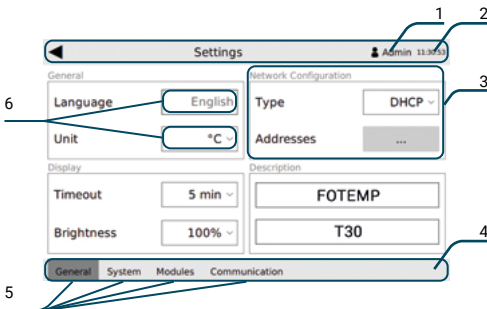

Figure 8: Sample screen with explanation of software elements

Number	Element	Description
1	Login/Admin	Button to login, log out or change the password.
2	Screen header	The screen header is displayed in every software view. The name of the screen you are viewing, login information and the current time are displayed. Use ◀ to go back to the screen overview.
3	Section	Screens can contain different sections. The sections are marked by a grey frame and a section title.
4	Bottom navigation bar	Use the bottom navigation bar to navigate between the sub-screens.
5	Sub-screens	Some software screens are divided into sub-screens.
6	Input fields	Input fields are marked by a grey frame or filling and a description on their left.

Input and navigation tools

The software can either be operated by the touchscreen or by the keypad on the FOTEMP T30 front panel. Depending on the entry you want to make, different keypads, input or selecting options are displayed. The different options are explained using examples from the FOTEMP T30 software.

Alphanumeric keypad

The alphanumeric keypad is displayed to perform the following tasks:

- Enter or change the password.
- Change the description of a channel.
- Change the description of the device.

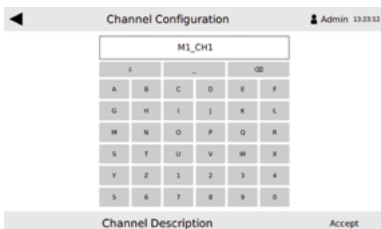

Figure 9: Example of alphanumeric keypad

To enter a new input using the alphanumeric keypad:

1. Select the input field to be changed.
  - ↳ The alphanumeric keypad appears.
2. Toggle between upper/lower case characters using ⇧ or ⇩.
3. Delete characters with ✕.
4. Confirm the entry by pressing Accept.
  - ↳ The new entry is saved.

Numeric keypad

The numeric keypad is displayed to perform the following tasks:

- Set a temperature.
- Set a monitoring interval.
- Change any other numeric parameter.

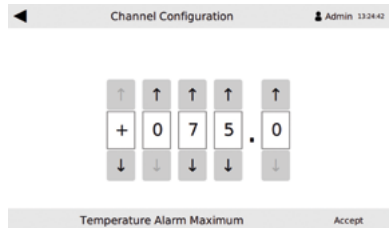

Figure 10: Example of numeric keypad

To enter a new numeric input, perform the following steps:

1. Select the input field to be changed.
  - ↳ The numeric keypad appears.
2. Use ⇧ or ⇩ to change the numbers or the sign.
3. Confirm the entry by pressing Accept.
  - ↳ The new entry is saved.

Dropdown list

The dropdown list is displayed whenever it is possible to select between more options from a list. You can recognize dropdown lists by the dropdown arrow in the input field.

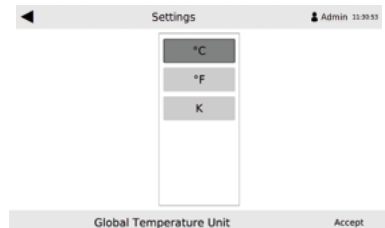

Figure 11: Example of a dropdown list

To choose an option from a dropdown list, perform the following steps:

1. Click on the dropdown arrow ▼ in the input field.
  - ↳ A list with all possible options arises.
2. Select an option from the list by clicking on the desired field.
3. Click Accept to confirm your selection.
  - ↳ The selected option is saved.

## Login and password



Technician

### Login



The default password corresponds to the last four numbers of your FOTEMP T30 serial number.



- For the first login, get the serial number of your FOTEMP T30 ready.

To log in to the FOTEMP T30 software:

- Press the *Login button* in the screen header.
  - The login keypad opens.
- Enter your password.
- Confirm your entry with *Accept*.
  - The description of the *Login button* turns into *Admin*.
  - Access to all screens is unlocked.

### Change the password



The password length must not exceed 20 characters. Take note of the new password!

After the first login, perform the following steps to change the password:

Step To Do	Result
------------	--------

- |   |                                                     |                                                                                                                                                                             |
|---|-----------------------------------------------------|-----------------------------------------------------------------------------------------------------------------------------------------------------------------------------|
| 1 | Press the <i>Admin button</i> in the screen header. | <ul style="list-style-type: none"> <li>The <i>Administration</i> screen opens.</li> </ul>  |
|---|-----------------------------------------------------|-----------------------------------------------------------------------------------------------------------------------------------------------------------------------------|



Figure 12: Administration screen

- |   |                                 |                                                                                                                                                                                |
|---|---------------------------------|--------------------------------------------------------------------------------------------------------------------------------------------------------------------------------|
| 2 | Select <i>Change Password</i> . | <ul style="list-style-type: none"> <li>The <i>Change Password</i> screen opens.</li> </ul>  |
|---|---------------------------------|--------------------------------------------------------------------------------------------------------------------------------------------------------------------------------|

Figure 13: Change password screen

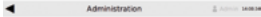
- |   |                                                                 |                                                                            |
|---|-----------------------------------------------------------------|----------------------------------------------------------------------------|
| 3 | Select <i>old</i> and enter the old password.                   |                                                                            |
| 4 | Click <i>Accept</i> to confirm your entry.                      |                                                                            |
| 5 | Select <i>new</i> and enter the new password.                   |                                                                            |
| 6 | Click <i>Accept</i> to confirm your entry.                      |                                                                            |
| 7 | Select <i>confirm</i> and enter the new password a second time. |                                                                            |
| 8 | Click <i>Accept</i> to confirm your entry.                      |                                                                            |
| 9 | Confirm all your changes by clicking <i>Accept</i> .            | <ul style="list-style-type: none"> <li>The new password is set.</li> </ul> |

## Change the password



The password can be reset only by COMEM! Take note of your new password!

### Logout



An automatic logout takes place after a defined idle time. The auto-logout time corresponds to the *Display Timeout*.



For more information about how to modify the auto-logout time, see chapter 5.3.4 Set the display timeout.

To log out from the perform the following steps:

- Press the *Admin button* in the screen header.
  - The *Administration* screen opens (Figure 12).
- Click *Logout*.
  - You are logged out from the FOTEMP T30 software.

### Define the settings



Technician

#### Change the software language

This software version is currently available only in English; you cannot change the language.

#### Change the temperature unit



The use of degrees Fahrenheit can lead to rounding errors because the measured values are stored internally in degrees Celsius.

To change the temperature unit, perform the following steps:

- Open the *Settings* screen.
  - The *General settings* screen opens.

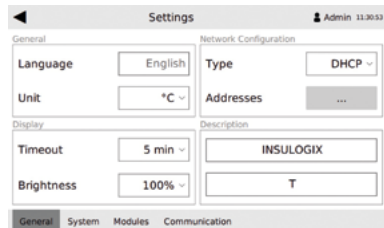
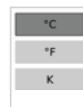

Figure 14: General settings screen

- In the section *General*, select a temperature unit from the dropdown list.



- To confirm your selection, click *Accept*.
  - The chosen unit is saved.

## Define the network configuration



Only Internet Protocol Version 4 (IPv4) is supported.

To change the network configuration, perform the following steps:

1. Open the Settings screen.
  - ↳ The *General settings* screen opens (Figure 14).
2. In the section *Network Configuration*, select between *DHCP* and *Manual* using the dropdown list.

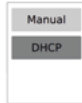

3. To confirm your selection, click *Accept*.
4. To set the IP address manually click on *...*.
  - ↳ The *Network Configuration* screen opens.

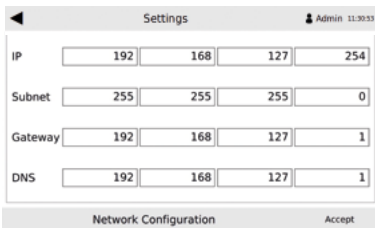

Figure 15: Network configuration screen

5. Set the configuration using the numeric keypad displayed on the touch screen.
6. Confirm your entries by clicking *Accept*.
  - ↳ The network configuration is defined.

## Set the display timeout

The *Display Timeout* corresponds to the time before the display turns off.



When the set *Display Timeout* time elapses, the Admin will be automatically logged out. If the *Display Timeout* is switched off, the Admin will still be logged out after 30 minutes.

To set or change the display timeout:

1. Open the Settings screen.
  - ↳ The *General settings* screen opens (Figure 14).
2. In the section *Display*, click on the dropdown arrow next to *Timeout*.
3. Choose an option from the dropdown list.



4. Confirm your selection by clicking *Accept*.
  - ↳ The selected display timeout is applied.

## Change the display brightness

To modify the display brightness:

1. Open the Settings screen.
  - ↳ The *General settings* screen opens (Figure 14).
2. In the section *Display*, click on the dropdown arrow and choose an option from the displayed list.

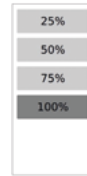

3. Confirm your selection by clicking *Accept*.
  - ↳ The selected display brightness is applied.

## Modify the device description

The description of the device corresponds to your device's name which is displayed on the log files. The description consists of two lines that can be modified separately. To change the description of your FOTEMP T30 device, perform the following steps:

1. Open the Settings screen.
  - ↳ The *General setting* screen opens (Figure 14).
2. In the section *Description*, select the desired line to modify the entries.
3. Enter the new device description by using the alphanumeric keypad displayed on the touch screen.
4. Confirm your entries by clicking *Accept*.
  - ↳ The new description of your device is saved.

## Change or synchronize date and time



No daylight-saving functionality is implemented.  
No time zone support is implemented.

Date and time are displayed in ISO 8601 format: "year-month-day hour:minute:second".

To change or synchronize date and time, proceed as follows:

1. Open the Settings screen.
2. Select the *System* sub-screen using the bottom navigation bar.
  - ↳ The *System settings* screen opens.

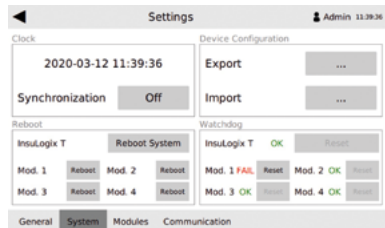

Figure 16: System settings screen

3. Click *Off* next to *Synchronization* in the section *Clock*.
  - ↳ The *Date & Time Synchronization* screen opens.

The screenshot shows a 'Date & Time Synchronization' screen. At the top, there is a 'Synchronization' toggle set to 'Off' and an 'NTP' label. Below this, there are two columns: 'Date' and 'Time'. The 'Date' column has input fields for 'Day' (9), 'Month' (9), and 'Year' (20). The 'Time' column has input fields for 'Hour' (19), 'Minute' (17), and 'Second' (33). Below these fields is a 'Timeserver' field containing '0.debian.pool.ntp.org'. At the bottom, there is a title bar 'Date & Time Synchronization' with an 'Accept' button on the right. Below the title bar is a navigation bar with four tabs: 'General', 'System', 'Modules', and 'Communication' (which is currently selected).

Figure 17: Date & time synchronization screen

4. Modify date and time manually with the displayed numeric keypad or click *NTP* to synchronize date and time by using NTP Network Time Protocol.
  5. Click *Accept* to confirm your entries.
- ↳ Date and time are set according to your entries.

### Export/import the device configuration

The configuration of the FOTEMP T30 can be transferred to another device. Therefore, the current settings can be saved as an "init.xml" file on an external USB storage device.

The following configurations are exported/imported:

- Channel Configuration
- Relay Configuration
- Monitoring Interval
- Settings

### Export the device configuration to external USB storage



Prepare an external USB storage device.

To export the current device settings, proceed as follows:

1. Open the *Settings* screen.
2. Select the *System* sub-screen using the bottom navigation bar.
  - ↳ The *System settings* screen opens (Figure 16).
3. In the section *Device Configuration* click on **...** next to *Export*.
  - ↳ An export screen opens.
4. Insert an external USB storage device.
  - ↳ If no USB storage is connected, the following message is displayed: *Hint: External storage is not available.*
  - ↳ If a configuration file is already stored on the USB storage, the following message is displayed: *Hint: File init.xml exists on external storage and will be overwritten.*
5. Press *Export* in the bottom navigation bar.
  - ↳ The device configuration is saved on USB storage and the message *Export Successful* appears.

### Import the device configuration from an external USB storage



The import of a configuration only runs correctly if the devices are identical in construction, i.e. they have the same number of modules, the same number of channels per module and so on. The imported settings replace the existing configuration of the device.



Prepare the configurations you want to import on an external USB storage device.

To import a device configuration, proceed as follows:

1. Open the *Settings* screen.
2. Select the *System* sub-screen using the bottom navigation bar.
  - ↳ The *System settings* screen opens (Figure 16).
3. In the section *Device Configuration* click on **...** next to *Import*.
  - ↳ If no USB storage is connected, the following message is displayed: *Hint: External storage is not available.*
  - ↳ If a configuration file is found on the USB device, the following message is displayed: *Hint: Found file init.xml. Can import data.*
5. Press *Import* in the bottom navigation bar.
  - ↳ The configuration is imported to your device and the message *Import Successful* appears.

### Reboot the device or the modules

#### Reboot the FOTEMP T30 device

To import a device configuration, proceed as follows:

1. Open the *Settings* screen.
  2. Select the *System* sub-screen using the bottom navigation bar.
    - ↳ The *System settings* screen opens (Figure 16).
  3. In the section *Reboot*, click and hold the *Reboot System* button for 3 seconds.
    - ↳ The reboot process is indicated by a progress bar.
- ↳ The FOTEMP T30 has successfully rebooted.

#### Reboot a single module

To reboot a single module, proceed as follows:

1. Open the *Settings* screen.
  2. Select the *System* sub-screen using the bottom navigation bar.
    - ↳ The *System settings* screen opens (Figure 16).
  3. In the section *Reboot*, click and hold the *Reboot* button next to the chosen module for 3 seconds.
    - ↳ The reboot process is indicated by a progress bar.
- ↳ The desired module has successfully rebooted.

### Check or reset the watchdog

The watchdog is a timer used to detect and recover from system malfunctions. During normal operation, the system regularly resets the watchdog timer. If, due to an error, the system fails to reset the watchdog, the timer will elapse and generate a timeout signal. The message FAIL will be displayed.

If a module or the whole FOTEMP T30 device shows normal operation, the Reset button is greyed out and the message OK is displayed.

To reset the watchdog, proceed as follows:

1. Open the *Settings* screen.
2. Select the *System* sub-screen using the bottom navigation bar.
  - ↳ The *System settings* screen opens (Figure 16).
3. Check the watchdog status FAIL/OK In the section *Watchdog*.
4. If a FAIL message is displayed, click and hold the corresponding *Reset* button for 3 seconds.
  - ↳ The reset process is indicated by a progress bar.

↳ The watchdog for the device or the module is reset.

If the watchdog reset fails:

1. Reboot the device.



Find information about how to reboot the device in chapter 5.3.9 Reboot the device or the modules.

2. If the FAIL message remains, contact COMEM.

### View the lamp and spectrum settings



Do not change the parameters *Spectrum Averaging*, *Spectrum Smoothing* and *Lamp Delay* without permission from COMEM as these parameters affect the factory calibration and accuracy of readings. Doing so may void the warranty.

The values *Spectrum Averaging*, *Spectrum Smoothing* and *Lamp Delay* are set by the manufacturer before delivery.

To view the lamp and spectrum settings, proceed as follows:

1. Open the *Settings* screen.
2. Select the *Modules* sub-screen using the bottom navigation bar.
  - ↳ The following screen opens.

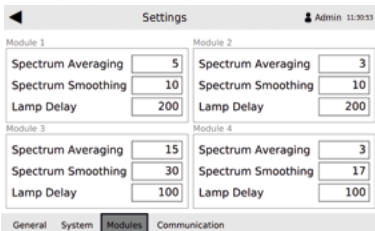

Figure 18: Modules settings screen

↳ The spectrum and lamp settings are displayed for each module.

### Define the communication protocol parameters

In the *Communication* sub-screen, the parameters can be defined for the various communication protocols that are activated on the FOTEMP T30. Communication protocol parameters can only be modified for the protocols that are activated/licensed on your device.



Find information about the communication protocol settings and addresses, in the Annex-Communication protocols.

Communication options must be defined at the time of order so these can be licensed prior to shipping from the factory.

To define the communication protocol parameters:

1. Open the *Settings* screen.
2. Select the *Communication* sub-screen using the bottom navigation bar.
  - ↳ The *Communication settings* screen opens.



Figure 19: Communication settings screen

3. Define the desired parameters by using the numeric keypad (for Modbus or DNP3 communication protocols) or the displayed *Export/Import* options (for IEC 61850 communication protocols).
4. Confirm your entries by clicking *Accept*.
  - ↳ The communication protocol parameters are applied.

### Configure the channels



Technician

#### Enable/disable the display of a channel

To enable or disable a channel from being displayed in the *Overview* screen:

1. Open the *Channel Config* screen.
2. Select desired module and channel from the displayed list.
  - ↳ The *Channel Configuration* screen opens.

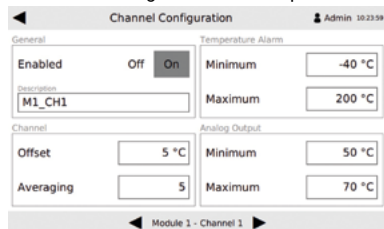

Figure 20: Channel configuration screen

3. In the section *General*, click *Off* to disable or *On* to enable the channel display.
  - ↳ The desired channel is enabled/disabled from being displayed.

**Modify the channel description**

To modify the channel description, proceed as follows:

1. Open the *Channel Config* screen.
2. Select desired module and channel.
  - ↳ The *Channel Configuration* screen opens (Figure 20).
3. In the section *General*, modify the *Description* by using the displayed keypad.
4. Confirm your entry by clicking *Accept*.
  - ↳ The desired channel description is modified.

**Set a temperature alarm**

A temperature alarm can be set by entering a minimum and maximum temperature for each channel. The accepted temperature range lies between -40 °C and 200 °C. If the measured temperature value lies outside the defined range the corresponding entry in the Overview screen will turn red (Figure 27).

To set a temperature alarm, perform the following steps:

1. Open the *Channel Config* screen.
2. Select desired module and channel.
  - ↳ The *Channel Configuration* screen opens (Figure 20).
3. In the section *Temperature Alarm*, click on the desired input field.
4. Enter a temperature by using the displayed numeric keypad.
5. Confirm your entries by clicking *Accept*.
  - ↳ A new temperature alarm is set.

**Adjust the temperature using an offset**

The measured temperature can be adjusted by using an offset. The temperature offset can be set individually for each channel. A positive offset value is added to the measured temperature and a negative value is subtracted from the measured temperature.

To set a temperature offset, perform the following steps:

1. Open the *Channel Config* screen.
2. Select desired module and channel.
  - ↳ The *Channel Configuration* screen opens (Figure 20).
3. In the section *Channel*, click on the input field next to *Offset*.
4. Enter a temperature offset by using the displayed numeric keypad.
5. Confirm your entry by clicking *Accept*.
  - ↳ A temperature offset is set.

**Define the averaging of readings**

To define the number of measured values for Averaging, proceed as follows:

1. Open the *Channel Config* screen.
2. Select desired module and channel.
  - ↳ The *Channel Configuration* screen opens (Figure 20).
3. In the section *Channel*, click on the input field next to *Averaging*.
4. Enter a value between 2 and 10 by using the displayed numeric keypad.
5. Confirm your entry by clicking *Accept*.
  - ↳ The *Averaging* settings are applied.

**Define the averaging of readings**

The current output of the device is between 4...20 mA DC and the voltage output between 0...10 V DC. Toggling between current and voltage outputs cannot be done through the user interface. This requirement shall be defined at the time of order.

To define the *Minimum* and *Maximum* temperature scaling parameters for the analog outputs, proceed as follows:

1. Open the *Channel Config* screen.
2. Select desired module and channel.
  - ↳ The *Channel Configuration* screen opens (Figure 20).
3. In the section *Analog Output*, click on the desired input field.
4. Enter a value by using the displayed numeric keypad.
5. Confirm your entry by clicking *Accept*.
  - ↳ The *Analog Output* settings are applied.

**Configure the channels**



Technician

**Explanation of logic conditions and logic groups**

To define the relay switching state, you can configure a logical expression using the following parameters:

- Temperature limit
- Module watchdog
- Device watchdog.

Device watchdog.

Logic conditions are linked with a logical AND to form a logic group.

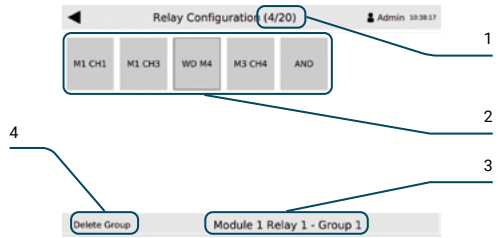

Figure 21: Example of a relay logic group consisting of four conditions.

- |   |                                                                    |
|---|--------------------------------------------------------------------|
| 1 | Four out of 20 possible conditions are defined.                    |
| 2 | Different conditions linked with a logical AND form a logic group. |
| 3 | Currently selected logic group.                                    |
| 4 | Delete the current logic group.                                    |

All defined logic groups are linked with a logical OR. The resulting logical expression defines the overall switching state of the relay.

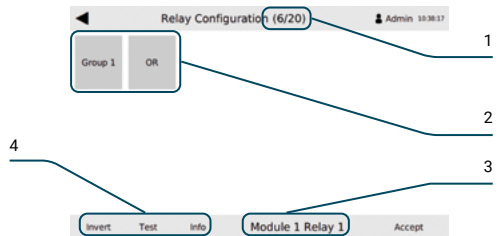

Figure 22: Example for a relay switching state consisting of two logic groups.

- 1 Six of a possible 20 conditions to define the logic groups are already used.
- 2 Logic groups are linked with a logical OR.
- 3 Currently selected module and relay.
- 4 Use these buttons to invert, test or display the logic expression of the relay.

**Configure the channels**



You can define up to 20 logic groups or logic conditions. If the maximum number of logic groups and logic conditions is reached, the + button will be grayed out.

To define a new logic group, proceed as follows:

1. Open the *Relay Config* screen.
  2. Select desired module and relay.
  3. Press the + button twice.
- ↳ The following screen opens.

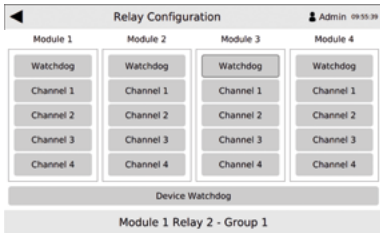

Figure 23: Relay logic conditions selection

4. Set a module or device *Watchdog* by selecting the corresponding option.
- To set a temperature limit at which the relay switches, select the desired *Channel*.
- ↳ The following screen opens.

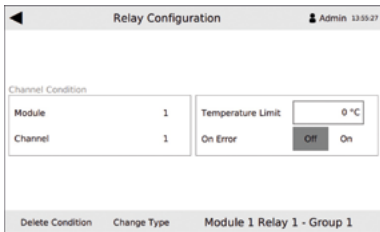

Figure 24: Relay channel condition selection

5. Set the *Temperature Limit* using the displayed numeric keypad.
  6. Click *Accept* to confirm your entry.
  7. To include relay switching if an error on the channel occurs, press *On*.
- ↳ If both values are set, the relay switches to true if one of the two states occur.
8. Click *Accept* to confirm your entries.
- ↳ A new logic group is added.

**Invert the relay configuration**

To invert the defined switching state of a relay, proceed as follows:

1. Open the *Relay Config* screen.
  2. Select desired module and relay.
- ↳ The defined logic groups are displayed.
3. Select *Invert* using the bottom navigation bar.
  4. Confirm your changes by clicking *Accept*.
- ↳ The defined switching state of the relay is inverted.

**Test the relay configuration**

Use the *Test* option to disable the relay logic temporarily so that the relay can be switched manually.

To test the relay configuration, perform the following steps:

1. Open the *Relay Config* screen.
  2. Select desired module and relay.
- ↳ The defined logic groups are displayed.
3. Select *Test* using the bottom navigation bar.
- ↳ The following screen opens:

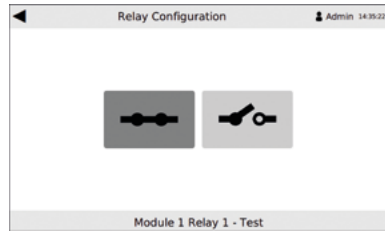

Figure 25: Relay test screen

4. Click on or to change the position of the relay.
- ↳ The relay is switched manually.

**Display the logical expression of the relay**

To display the relay logic as plain text with logical expressions, proceed as follows:

1. Open the *Relay Config* screen.
  2. Select desired module and relay.
- ↳ The defined logic groups are displayed.
3. Select *Info* using the bottom navigation bar.
- ↳ The following screen opens:

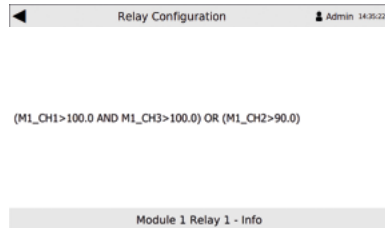

Figure 26: Relay logical expression

- ↳ The relay logic is displayed as plain text.

Display current temperatures and relay positions



Operator



Red entries in the *Overview* screen always indicate an error.

- Red number: temperature is outside the set alarm limit.
- ERROR: a problem with module or connected temperature sensor occurred.

To display the current temperature and relay position:

- ◆ Open the *Overview* screen.

↪ An overview over the current temperature and relay position of all installed modules and channels is displayed (Figure 27).

Displaying options

Change between the different display options using the bottom navigation bar.

- Full: all installed modules and channels are displayed.
- Module: one module is displayed per time.
- Channel: one channel is displayed per time, starting from module 1, channel 1.
- Roll: in the Module screen and in the Channel screen the Roll mode can be activated. In the Roll mode the displayed modules or channels change automatically after four seconds.

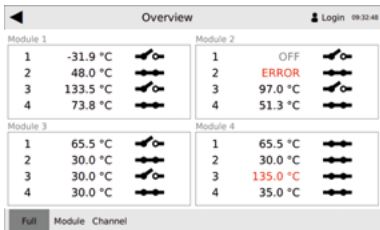

Figure 27: Overview screen with current temperature and relay position

Display element	Description
OFF	The channel display is disabled.
ERROR	Indicates a problem with the module or the connected sensor.
	Relay position open.
	Relay position closed.
135.0 °C	The measured temperature lies outside the defined alarm range.



Learn more about error messages in chapter 7 Troubleshooting.

Display information about the product



Operator

To find information about the product, serial numbers and manufacturer:

- ◆ Open the *About* screen.

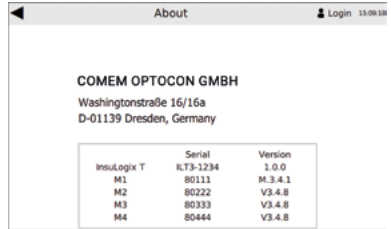

Figure 28: About screen

↪ Manufacturer's address, serial number of device and installed modules are displayed.

Record temperature data



Technician

Set a monitoring interval

The time interval for data recording is specified in Days, Hours, Minutes and Seconds. The monitoring interval applies to all active channels.

To set a monitoring interval, proceed as follows:

1. Open the *Monitoring* screen.
2. In the section *Interval*, click on the desired input field.



Figure 29: Monitoring screen

3. Enter the values by using the displayed numeric keypad.
  4. Confirm your entry by clicking *Accept*.
- ↪ The new monitoring interval is applied.

Enable/disable data recording

To activate or deactivate data recording:

1. Open the *Monitoring* screen (Figure 29).
  2. In the section *Status*, click on *Enabled* to activate data recording or on *Disabled* to deactivate data recording.
- ↪ The data recording is enabled or disabled.

## Check the available and used storage capacity

To display the storage capacity of your device, perform the following steps:

1. Open the *Monitoring* screen (Figure 29).
2. In the section *Status*, check the displayed memory capacity.
  - ↳ The used and the available memory capacity are displayed.

## Display current temperatures and relay positions



Already downloaded data (see chapter 5.8.5) is no longer displayed in the *Monitoring-Events* or *Monitoring-Temperatures* screens.

## Display recorded events

The default time interval for recording events is one minute. The following events and actions are recorded:

- Login/logout/auto-logout
- Temperature alarms
- Changes in the settings

To display recorded events, perform the following steps:

1. Open the *Monitoring* screen (Figure 29).
2. Select the *Show* sub-screen by using the bottom navigation bar.
  - ↳ The *Monitoring-Events* screen is displayed.

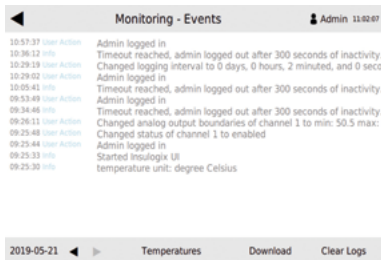

Figure 30: Monitoring-Events screen

3. Use ◀ and ▶ to display events from previous days.
  - ↳ All recorded events are displayed.

## Display recorded temperatures

To display recorded temperatures, perform the following steps:

1. Open the *Monitoring* screen (Figure 29).
2. Select the *Show* sub-screen by using the bottom navigation bar.
3. Click on *Temperatures* in the bottom navigation bar (Figure 30).
  - ↳ The *Monitoring-Temperatures* screen is displayed.

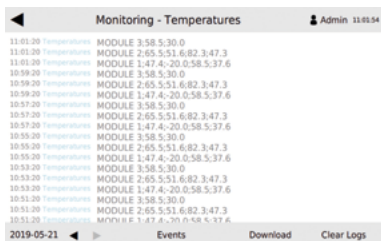

Figure 31: Monitoring-Temperatures screen

4. Use ◀ and ▶ to display temperatures from previous days.
  - ↳ The recorded temperatures of all connected temperature sensors are displayed.

## Download recorded data



## NOTICE

### Accidental formatting of USB storage device

Losing data due to formatting of USB storage device!

→ Save the data stored on your USB device before inserting it into the device. FAT32 and NTFS format are supported.

The measurement data is recorded in a log file in CSV file format. The CSV file is stored internally in the FOTEMP T30 device and can be downloaded via a USB interface.

The log files are divided into two categories:

- *Recent log files*: Internally stored files that have not yet been downloaded.
- *Downloaded (archived) files*: Internally stored files that have already been downloaded but not yet deleted.



The recorded data e.g. the log files, remain stored in the FOTEMP T30 after they have been downloaded and can therefore be downloaded several times. The log files will only be deleted when the Clear Logs action is performed (see chapter 5.8.7 Clear recorded data).



Prepare an external USB storage device.

To download data from FOTEMP T30, perform the following steps:

1. Open the *Monitoring* screen (Figure 29).
2. Select the *Download* sub-screen by using the bottom navigation bar.
  - ↳ The following *Download* screen appears.

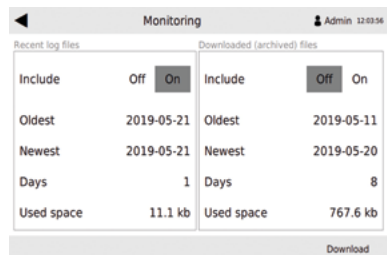

Figure 32: Download screen

3. Insert an external USB storage device.
  - ↳ If no USB storage is connected, the following message is displayed: *Please insert a USB-stick!*
4. To include recent log files, select On in the section *Recent log files*.
5. To include previously downloaded log files, select On in the section *Downloaded (archived) files*.
6. Press *Download* in the bottom navigation bar.
  - ↳ A folder named "logs" is created on your USB storage device.
  - ↳ All selected log files are downloaded as ".csv" files to your USB storage device.



The file for the current day is not yet complete. Therefore, the saved file on the USB storage will be marked with "incomplete".

**Open downloaded data in a spreadsheet editor**

The measurement data is recorded in CSV file format. Semicolons are used to separate the data fields in the CSV file. If your regional settings require commas in CSV files instead of semicolons, perform the following steps to change the separator:

1. Open the log file in a text editor.
  2. Find/replace all “;” with “,”.
  3. Save the file as “.csv”.
  4. Open the file in a spreadsheet editor.
- ↳ The log file opens correctly in your spreadsheet editor.

**Clear recorded data**

**NOTICE**

**Unintentional deletion of recorded data**  
 Losing recorded data due to accidental deletion of the log files!  
 → Download and backup recorded data regularly.  
 → Make sure you download the log files before you press the Clear button.

The log file for the current day cannot be deleted.

To clear recorded data, proceed as follows:

1. Open the *Monitoring* screen (Figure 29).
  2. Select the *Clear Logs* sub-screen by using the bottom navigation bar.
- ↳ The following screen appears:

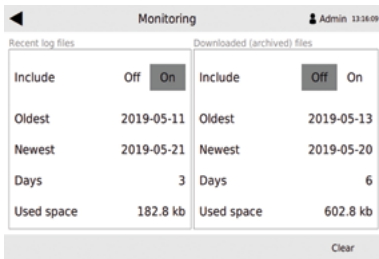

Figure 33: Delete log files

3. To clear the recent log files, select *On* in the section *Recent log files*.
  4. To clear already downloaded log files, select *On* in the section *Downloaded (archived) files*.
  5. Press *Clear* in the bottom navigation bar.
- ↳ All the selected log files are deleted from the internal storage of the FOTEMP T30 device.

# Maintenance

**Periodic inspection and data backup**



To guarantee a proper operation, perform the following steps at constant intervals depending on the usage of the device:

- Check the status LEDs.
- Check the current temperature and relay position.
- Check the log files for unexpected events.
- Backup the data on external USB storage.

**Clean the device**



**NOTICE**

**Cleaning agents**  
 Damage to the device by using inappropriate cleaning agents!  
 → Do not use cleaning agents directly on the device.  
 → Do not use solvents or abrasive agents to clean the touch screen.  
 → Do not use compressed air to clean the device.

To clean the FOTEMP T30:

- ◆ Wipe the device with a dry cloth.

To clean plug and socket of fiberoptic connections:

- ◆ Use the supplied cleaning tool and follow the provided instructions.

**Replace or install a new measurement module**



A detailed installation description will be provided together with the new module.

**Repair, firm- and software updates**



Contact COMEM for the following tasks:

- To replace the built-in battery.
- To get firm- and software updates.
- For any other repair work.

## Re-adjust the temperature



Technician

A one-point-temperature-correction can be performed using the offset function of the FOTEMP T30 software.



To set or change the temperature offset, see chapter 5.4.4 Adjust the temperature using an offset.

## Calibration



COMEM service

Calibration is performed by COMEM during the manufacturing process. Recalibration is typically not required over the entire life of the device.

For high-accuracy applications a periodic recalibration of the device and sensor combination is recommended.

Problem	LED color	Problem-solving steps
Storage capacity on the internal SD card is less than 10%	Yellow	◆ Clear log memory or download logs (see chapters 5.8.5 and 5.8.7)
Interface error – interface process not operating (IEC61850 or Modbus)	Yellow	◆ IEC61850 Check settings (see Annex -IEC61850) Contact COMEM if necessary.
The watchdog has been set for one of the modules or the main application during crash and/or reboot	Red	◆ Reset the watchdog for the modules and the main application within the settings (5.3.10) Check log, contact COMEM if necessary.
Device does not start	None	◆ Check the power supply.
Device does not show measurement values	None	◆ Reboot device (software or hardware) See “Channel Error”.
Device reboots constantly	None	◆ Check IP settings.

# Troubleshooting



Technician

If an error occurs during the operation, perform the following steps:

1. Carry out the problem-solving steps listed in the table below.
2. If not successful, contact COMEM.

Problem	LED color	Problem-solving steps
Channel error while reading the temperature (ERROR message on Overview screen)	Yellow	<ol style="list-style-type: none"> <li>1. Check the light source of fiber optic connectors: if more than one sensor is configured per module, the socket should blink at least once per second. If only one sensor is configured, a constant light (white-yellow) should be visible. If a light is visible, proceed with step 2. If no light is visible, the module is defective; contact COMEM for replacement.</li> <li>2. Clean fiber optic connectors with alcoholic cleaning substances. If there is no success, proceed with step 3 to check the fiber for damage.</li> <li>3. Check fiber for breaks using a fiber optic fault detector (high power laser source invisible range). In case of break detection, replace the fiber optic cable.</li> </ol>

# Disposal

The device was manufactured in accordance with the European Community Directive RoHS2011/65/EU (Restriction of the Use of Certain Hazardous Substances in Electronic and Electrical Equipment) and must be disposed of accordingly. If the device is not operated within the European Union, the national disposal regulations applicable in the country of use should be observed.



The device contains a lithium coin cell battery. Batteries should never be disposed of with normal household waste!



Find more information about the materials used in chapter 9 Technical data.

Correct disposal avoids negative effects on persons and environment and ensures recycling of useful raw materials. Contact COMEM for more information about the correct disposal of your device.

# Communication protocols

## Modbus

Note: The Modbus specification version is 1.3.  
This is the full Modbus data map for an FOTEMP T30. Therefore, all module-, channel- and relay-specific registers are designed for their maximum. If your device does not have a certain number of modules, channels or relays, access to the respective addresses will fail.

## Settings

Parameter	Value
Parameter	Value
ID (default)	Specify on GUI (1)
Baudrate	115200
Stopbits	1
Parity	None
Port (Ethernet)	502
Interface	RS485 HX or Ethernet

## Addresses

### Discrete Output Coils

Function	Address	R/W	Description	Type
Enable Channel [K1-16]	0x001 – 0x010	X / X	0: Channel off 1: Channel on	bit
Auto Integration [M1-4]	0x010 – 0x013	X / X	0: Constant Exposure Time 1: Auto tuning	bit
Log Mode	0x014 – 0x014	X / X	0: Logging deactivated 1: Logging activated	bit
Erase Archive Log Data	0x015 – 0x015	- / X	1: Erase archive log data	bit
Erase Log Data	0x016 – 0x016	- / X	1: Erase log data	bit
Module Watchdog Reset [M1-4]	0x017 – 0x01A	- / X	1: Reset Watchdog in Modules	bit
Module Reboot [M1-4]	0x01B – 0x01E	- / X	1: Reboot Modules	bit
Device Reboot	0x01F – 0x01F	- / X	1: Reboot Device	bit

### Discrete Input Coils

Function	Address	R/W	Description	Type
Alarm State [K1-16]	0x000 – 0x00F	X / -	0: Condition not met 1: Condition met	bit
Relay State [R1-16]	0x010 – 0x01F	X / -	0: Relay open 1: Relay closed	bit
Module Watchdog [M1-4]	0x020 – 0x023	X / -	0: Module OK 1: Module Watchdog raised	bit
Device Watchdog	0x024 – 0x024	X / -	0: Device OK 1: Device Watchdog raised	bit

## Analog Input Registers

Function	Address	R/W	Description	Type
Edge [K1-16]	0x000 – 0x00F	X / –		unsigned int
Temperature [K1-16]	0x010 – 0x01F	X / –	Channel temperature (tenths °C)	signed int
Error [K1-16]	0x020 – 0x02F	X / –	0: Channel OK, 1: No Sensor, 2: No Signal, 3: Signal too low, 4: Signal too high, 5: Channel off	unsigned int
Module Count	0x030 – 0x030	X / –		unsigned int
Module Location	0x031 – 0x031	X / –	Bit-masked	bit array
Channel Count	0x032 – 0x032	X / –		unsigned int
Channel Location	0x033 – 0x033	X / –	Bit-masked	bit array
Relay Count	0x034 – 0x034	X / –		unsigned int
Relay Location	0x035 – 0x035	X / –	Bit-masked	bit array
Device Temperature	0x036 – 0x036	X / –	CPU temperature (tenths °C)	unsigned int
Internal Space Usage	0x037 – 0x038	X / –	32-bit value for number of used bytes	unsigned int
Internal Space Size	0x039 – 0x03A	X / –	32-bit value for number of used bytes	unsigned int

## Analog Output Holding Registers

Function	Address	R/W	Description	Type
Temperature Offset [K1-16]	0x000 – 0x00F	X / X	Write value is a delta to the existing one (tenths °C)	signed int
Temperature Averaging [K1-16]	0x010 – 0x01F	X / X	Number of values for the Average Temperature	unsigned int
Analog Low Temp. [K1-16]	0x020 – 0x02F	X / X	(°C)	signed int
Analog High Temp. [K1-16]	0x030 – 0x03F	X / X	(°C)	signed int
Alarm Low Temp. [K1-16]	0x040 – 0x04F	X / X	(tenths °C)	signed int
Alarm High Temp. [K1-16]	0x050 – 0x05F	X / X	(tenths °C)	signed int
Integration Time [K1-16]	0x060 – 0x06F	X / X	When Auto Integration is active, without effect	unsigned int
Spectrum Average Count [M1-4]	0x070 – 0x073	X / X	Amount of accumulate Spectra	unsigned int
Spectrum Smoothing Factor [M1-4]	0x074 – 0x077	X / X	Matrix size of the smoothing algorithm	unsigned int
Next Lamp Delay [M1-4]	0x078 – 0x07B	X / X	Preheating time before a measure starts	unsigned int
Real Time Clock	0x07C – 0x07F	X / X	64-bit Unix timestamp	unsigned int
Log Interval	0x080 – 0x081	X / X	32-bit Unix timestamp	unsigned int
Relay Invert [R1-R16]	0x082 – 0x082	X / X	Bit-masked	bit array
Relay 1 Configuration	0x083 – 0x0AA	X / X	20 possible relay conditions per relay.	relay type
	...		All conditions per relay will be arranged without gaps in the address area when data is read.	
Relay 16 Configuration	0x2DB – 0x302	X / X		

## Function code FC43 – read controller identification

Object Id	Object Name	Category
Object Id	Object Name	Category
0x00	Vendor Name	Basic
0x01	Product Code	Basic
0x02	Major Minor Revision	Basic
0x03	Vendor URL	Regular
0x04	Product Name	Regular
0x05	Model Name	Regular
0x80 - 0x81	M1: Serial number / Firmware version	Extended
0x82 - 0x83	M2: Serial number / Firmware version	Extended
0x83 - 0x84	M3: Serial number / Firmware version	Extended
0x85 - 0x86	M4: Serial number / Firmware version	Extended

**DNP3**

Note: The DNP3 specification version is 1.3.

This is the full DNP3 data map for an FOTEMP T30. Therefore, all module-, channel- and relay-specific registers are designed for their maximum. If your device does not have a certain number of modules, channels or relays, access to the respective addresses will fail.

**Settings**

Parameter	Value
Master Address (default)	Specify on GUI (1024)
Outstation Address (default)	Specify on GUI (0)
Baudrate	115200
Stopbits	1
Parity	None
Port (Ethernet)	20000
Interface	RS485 FX or Ethernet

**Addresses****Binary Outputs****Object Group 10: Binary Output Static**

Function	Address	Variation	Description	Type
Enable Channel [K1–16]	0x000 – 0x00F	1	0: Channel off 1: Channel on	bit
Auto Integration [M1–4]	0x010 – 0x013	1	0: Constant Exposure Time 1: Auto tuning	bit
Log Mode	0x014 – 0x014	1	0: Logging deactivated 1: Logging activated	bit

**Object Group 12: Binary Output Command**

Function	Address	Variation	Description	Type
Enable Channel [K1–16]	0x000 – 0x00F	1	0: Channel off 1: Channel on	bit
Auto Integration [M1–4]	0x010 – 0x013	1	0: Constant Exposure Time 1: Auto tuning	bit
Log Mode	0x014 – 0x014	1	0: Logging deactivated 1: Logging activated	bit
Erase Archive Log Data	0x015 – 0x015	1	1: Erase archive log data	bit
Erase Log Data	0x016 – 0x016	1	1: Erase log data	bit
Module Watchdog Reset [M1–4]	0x017 – 0x01A	1	1: Reset Watchdog in Modules	bit
Module Reboot [M1-4]	0x01B – 0x01E	1	1: Reboot Modules	bit
Device Reboot	0x01F – 0x01F	1	1: Reboot Device	bit

**Binary Input****Object Group1: Binary Input Static**

Function	Address	Variation	Description	Type
Alarm State [K1–16]	0x020 – 0x02F	1	0: Condition not met 1: Condition met	bit
Relay State [K1–16]	0x030 – 0x03F	1	0: Relay open 1: Relay closed	bit
Module Watchdog [M1–4]	0x040 – 0x043	1	0: Module OK 1: Module Watchdog raised	bit
Device Watchdog	0x044 – 0x044	1	0: Device OK 1: Device Watchdog raised	bit

**Analog Input****Object Group 30: Analog Input Static**

Function	Address	Variation	Description	Type
Edge [K1-16]	0x045 – 0x054	4		unsigned int
Temperature [K1-16]	0x055 – 0x064	4	Channel temperature (tenths °C)	signed int
Error [K1-16]	0x065 – 0x074	4	0: Channel OK, 1: No Sensor, 2: No Signal, 3: Signal too low, 4: Signal too high, 5: Channel off	unsigned int
Module Count	0x075 – 0x075	4		
Module Location	0x076 – 0x076	4	Bit-masked	bit array
Channel Count	0x077 – 0x077	4		unsigned int
Channel Location	0x078 – 0x078	4	Bit-masked	bit array
Relay Count	0x079 – 0x079	4		unsigned int
Relay Location	0x07A – 0x07A	4	Bit-masked	bit array
Device Temperature	0x07B – 0x07B	4	CPU temperature (tenths °C)	unsigned int
Internal Space Usage	0x07C – 0x07D	4	32-bit value for number of used bytes	unsigned int
Internal Space Size	0x07E – 0x07F	4	32-bit value for number of used bytes	unsigned int

**Analog Output****Object Group 40: Analog Output Status**

Function	Address	Variation	Description	Type
Temperature Offset [K1-16]	0x080 – 0x08F	2	Write value is a delta to the existing one (tenths °C)	signed int
Temperature Averaging [K1-16]	0x090 – 0x09F	2	Number of values for the Average Temperature	unsigned int
Analog Low Temp. [K1-16]	0x0A0 – 0x0AF	2	(°C)	signed int
Analog High Temp. [K1-16]	0x0B0 – 0x0BF	2	(°C)	signed int
Alarm Low Temp. [K1-16]	0x0C0 – 0x0CF	2	(tenths °C)	signed int
Alarm High Temp. [K1-16]	0x0D0 – 0x0DF	2	(tenths °C)	signed int
Integration Time [K1-16]	0x0E0 – 0x0EF	2	When Auto Integration is active, without effect	unsigned int
Spectrum Average Count [M1-4]	0x0F0 – 0x0F3	2	Amount of accumulate Spectra	unsigned int
Spectrum Smoothing Factor [M1-4]	0x0F4 – 0x0F7	2	Matrix size of the smoothing algorithm	unsigned int
Next Lamp Delay [M1-4]	0x0F8 – 0x0FB	2	Preheating time before a measure starts	unsigned int
Real Time Clock	0x0FC – 0x0FF	2	64-bit Unix timestamp	unsigned int
Log Interval	0x100 – 0x101	2	32-bit Unix timestamp	unsigned int
Relay Invert [R1-R16]	0x102 – 0x102	2	Bit-masked	bit array
Relay 1 Configuration	0x103 – 0x12A	2	20 possible relay conditions per relay.	relay type
	...		All conditions per relay will be arranged without gaps in the address area when data is read.	
Relay 16 Configuration	0x35B – 0x382	2		

**Object Group 41: Analog Output Command**

Function	Address	Variation	Description	Type
Temperature Offset [K1-16]	0x080 – 0x08F	2	Write value is a delta to the existing one (tenths °C)	signed int
Temperature Averaging [K1-16]	0x090 – 0x09F	2	Number of values for the Average Temperature	unsigned int
Analog Low Temp. [K1-16]	0x0A0 – 0x0AF	2	(°C)	signed int
Analog High Temp. [K1-16]	0x0B0 – 0x0BF	2	(°C)	signed int
Alarm Low Temp. [K1-16]	0x0C0 – 0x0CF	2	(tenths °C)	signed int
Alarm High Temp. [K1-16]	0x0D0 – 0x0DF	2	(tenths °C)	signed int
Integration Time [K1-16]	0x0E0 – 0x0EF	2	When Auto Integration is active, without effect	unsigned int
Spectrum Average Count [M1-4]	0x0F0 – 0x0F3	2	Amount of accumulate Spectra	unsigned int
Spectrum Smoothing Factor [M1-4]	0x0F4 – 0x0F7	2	Matrix size of the smoothing algorithm	unsigned int
Next Lamp Delay [M1-4]	0x0F8 – 0x0FB	2	Preheating time before a measure starts	unsigned int
Real Time Clock	0x0FC – 0x0FF	2	64-bit Unix timestamp	unsigned int
Log Interval	0x100 – 0x101	2	32-bit Unix timestamp	unsigned int
Relay Invert [R1-R16]	0x102 – 0x102	2	Bit-masked	bit array
Relay 1 Configuration	0x103 – 0x12A	2	20 possible relay conditions per relay. All conditions relay type per relay will be arranged without gaps in the address area when data is read.	relay type
	...			
Relay 16 Configuration	0x36F – 0x382	2		

**IEC60870-5**

Note: The IEC60870-5 specification version is 1.3.  
 This is the full iec60870-5 data map for a FOTEMP T30.  
 Therefore, all module-, channel- and re-lay-specific registers are designed for their maximum. If your device does not have a certain number of modules, channels or relays, access to the respective addresses will fail.

**Settings**

Parameter	Value
Common Address (default)	Specify over GUI (1)
Baud rate	115200
Stop bits	1
Parity	None
Port (Ethernet)	2404
Interface	RS485 FX or Ethernet

**Addresses****Single Values****1 - Single Point: M\_SP\_NA\_1**

Function	Address	Description	Type
Enable Channel [K1-16]	0x001 – 0x010	0: Channel off 1: Channel on	bit
Auto Integration [M1-4]	0x011 – 0x014	0: Constant Exposure Time 1: Auto tuning	bit
Log Mode	0x015 – 0x015	0: Logging deactivated 1: Logging activated	bit
Alarm State [K1-16]	0x021 – 0x030	0: Condition not met 1: Condition met	bit
Relay State [R1-16]	0x031 – 0x040	0: Relay open 1: Relay closed	bit
Module Watchdog [M1-4]	0x041 – 0x044	0: Module OK 1: Module Watchdog raised	bit
Device Watchdog	0x045 – 0x045	0: Device OK 1: Device Watchdog raised	bit

**45 - Single Command: C\_SC\_NA\_1**

Function	Address	Description	Type
Enable Channel (K1-16)	0x7D1 – 0x7E0	0: Channel off 1: Channel on	bit
Auto Integration [M1-4]	0x7E1 – 0x7E4	0: Constant Exposure Time 1: Auto tuning	bit
Log Mode	0x7E5 – 0x7E5	0: Logging deactivated 1: Logging activated	bit
Erase Archive Log Data	0x7E6 – 0x7E6	1: Erase archive log data	bit
Erase Log Data	0x7E7 – 0x7E7	1: Erase log data	bit
Module Watchdog Reset [M1-4]	0x7E8 – 0x7EB	1: Reset Watchdog in Modules	bit
Module Reboot [M1-4]	0x7EC – 0x7EF	1: Reboot Modules	bit
Device Reboot	0x7F0 – 0x7F0	1: Reboot Device	bit

**Measured Values****9 - Measured Value, Normalized Value: M\_ME\_NA\_1**

Function	Address	Description	Type
Edge [K1-16]	0x046 – 0x055		unsigned int
Temperature [K1-16]	0x056 – 0x065	Channel temperature (tenths °C)	signed int
Error [K1-16]	0x066 – 0x075	0: Channel OK, 1: No Sensor, 2: No Signal, 3: Signal too low, 4: Signal too high, 5: Channel off	unsigned int
Module Count	0x076 – 0x076		unsigned int
Module Location	0x077 – 0x077	Bit-masked	bit array
Channel Count	0x078 – 0x078		unsigned int
Channel Location	0x079 – 0x079	Bit-masked	bit array
Relay Count	0x07A – 0x07A		unsigned int
Relay Location	0x07B – 0x07B	Bit-masked	bit array
Device Temperature	0x07C – 0x07C	CPU temperature (tenths °C)	unsigned int
Internal Space Usage	0x07D – 0x07E	32-bit value for number of used bytes	unsigned int
Internal Space Size	0x07F – 0x080	32-bit value for number of used bytes	unsigned int
Temperature Offset [K1-16]	0x081 x 0x90	(tenths °C)	signed int
Temperature Averaging [K1-16]	0x091 x 0x0A0	Amount of values for the Average Temperature	unsigned int
Analog Low Temperature [K1-16]	0x0A1 – 0x0B0	(°C)	signed int
Analog High Temperature [K1-16]	0x0B1 – 0x0C0	(°C)	signed int
Alarm Low Temperature [K1-16]	0x0C1 – 0x0D0	(tenths °C)	signed int
Alarm High Temperature [K1-16]	0x0D1 – 0x0E0	(tenths °C)	signed int
Integration Time [K1-16]	0x0Ei – 0x0F0	When Auto Integration is active, without effect	unsigned int
Spectrum Average Count [M1-4]	0x0F1 – 0x0F4	Amount of accumulate Spectra	unsigned int
Spectrum Smoothing Factor [M1-4]	0x0F5 – 0x0F8	Matrix size of the smoothing algorithm	unsigned int
Next Lamp Delay [M1-4]	0x0F9 – 0x0FC	Preheating time before a measure starts	unsigned int
Real Time Clock	0x0FD – 0x100	64-bit Unix timestamp	unsigned int
Log Interval	0x101 – 0x102	32-bit Unix timestamp	unsigned int
Relay Invert [R1-R16]	0x103 – 0x103	Bit-masked	bit array
Relay 1 Configuration	0x104 – 0x12B	20 possible relay conditions per relay. All conditions per relay will be arranged without gaps in the address area when data is read.	relay type
	...		
Relay 16 Configuration	0x35C – 0x383		

**48 - Setpoint Command, Normalized Value: C\_SE\_NA\_1**

Function	Address	Description	Type
Temperature Offset [K1-16]	0x851 – 0x860	Write value is a delta to the existing one (tenths °C)	signed int
Temperature Averaging [K1-16]	0x861 – 0x870	Amount of values for the Average Temperature	unsigned int
Analog Low Temp. [K1-16]	0x871 – 0x880	(°C)	signed int
Analog High Temp. [K1-16]	0x881 – 0x890	(°C)	signed int
Alarm Low Temp. [K1-16]	0x891 – 0x8A0	(tenths °C)	signed int
Alarm High Temp. [K1-16]	0x8A1 – 0x8B0	(tenths °C)	signed int
Integration Time [K1-16]	0x8B1 – 0x8C0	When Auto Integration is active, without effect	unsigned int
Spectrum Average Count [M1-4]	0x8C1 – 0x8C4	Amount of accumulate Spectra	unsigned int
Spectrum Smoothing Factor [M1-4]	0x8C5 – 0x8C8	Matrix size of the smoothing algorithm	unsigned int
Next Lamp Delay [M1-4]	0x8C9 – 0x8CC	Preheating time before a measure starts	unsigned int
Real Time Clock	0x8CD – 0x8D0	64-bit Unix timestamp	unsigned int
Log Interval	0x8D1 – 0x8D2	32-bit Unix timestamp	unsigned int
Relay Invert [R1-R16]	0x8D3 – 0x8D3	Bit-masked	bit array
Relay 1 Configuration	0x8D4 – 0x8FB	20 possible relay conditions per relay. All conditions per relay will be arranged without gaps in the address area when data is read.	relay type
	...		
Relay 16 Configuration	0xB2C – 0xB53		

IEC61850

Note: The IEC61850 specification version is 1.3.

Settings

Parameter	Value
IED Name	Specify in the CID file
IP Address	
Subnet	
Gateway	
Interface	Ethernet

Addresses

MMS Tags

Function	Address	R/W	Description	Type
Temperature [K1-16]	STMP<K>. \$MX\$Tmp\$mag\$f	X / -		float
Error [K1-16]	STMP<K>. \$MX\$Tmp\$mq	X / -	0: Channel OK, 1: No Sensor, 2: No Signal, bit array 3: Signal too low, 4: Signal too high	bit array
Last Measurement [K1-16]	STMP<K>.\$MX\$Tmp\$t	X / -		utc time
Channel Enabled [K1-16]	STMP<K>. \$ST\$Beh\$stVal	X / -	1: Channel on 5: Channel off	Integer
Last Measurement [K1-16]	STMP<K>. \$ST\$Beh\$t	X / -		utc time
Alarm State [K1-16]	STMP<K>. \$ST\$Alm\$stVal	X / -		boolean
Last Measurement [K1-16]	STMP<K>. \$ST\$Alm\$t	X / -		utc time
Channel Enabled [K1-16]	STMP<K>. \$ST\$Mod\$stVal	X / -	1: Channel on 5: Channel off	integer
Enable Channel [K1-16]	STMP<K>. \$CO\$Mod\$Oper\$ctlVal (Set per Command)	- / X	1: Channel on 5: Channel off	integer
Temperature Offset [K1-16]	STMP<K>.\$SP\$TmpOffset\$setMag\$f	X / X	Read or write the value	float
Relay Exist [R1-R16]	GGIO<R>.\$ST\$Beh\$stVal	X / -	1: Relay exists 5: Relay does not exist	integer
Relay State [R1-R16]	GGIO<R>.\$ST\$Ind1\$stVal	X / -	True: Relay closed False: Relay opened	boolean
Relay Changed Time [R1-R16]	GGIO<R>.\$ST\$Ind1\$t	X / -		utc time

IED Structure

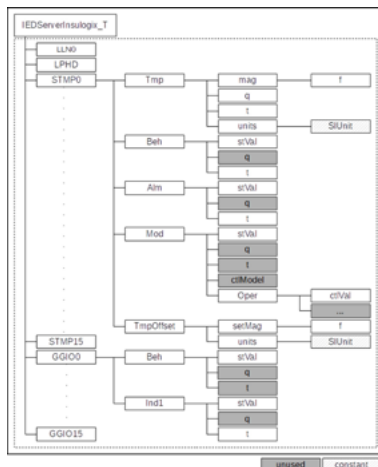

Figure 34: IED structure

## Ascii (Debug)

## Settings

Parameter	Value
Baud rate	57600
Stop bits	1
Parity	None
Newline	CR
Interface	RS232

## Commands

## Read Commands

Function	Command	Parameter	Return
Average Temperature	?01	X / X	
All Average Temperatures	?02	X / X	
Temperature	?03	X / X	
All Temperatures	?04	X / X	
Temperature + Timestamp	?05	X / X	
Error	?07	X / X	
Channel Count	?0F		Reserved for debug functionality
Channel Enabled	?10	X / X	
Channel Disturbed	?11	- / X	1: Reset Watchdog Relay
Actual Channel	?12	- / X	1: Reset RTC system registers
Integration Time	?23	- / X	1: Reset all RTC registers
Auto Integration	?26	- / X	1: Erase SD data
Next Lamp Delay	?27	- / X	1: Reboot
Model Name	?40		
Serial Number	?41		
Firmware Version	?42		
Library Version	?43		
Hardware Configuration	?46		
Spectrum Smoothing Factor	?50		
Spectrum Average Count	?52		
Temperature Averaging	?53		
Last Edge	?73		
Temperature Offset	?75		
Analog Limits	?81		
Relay State	?87		
Watchdog	?88		

## Write Commands

Function	Command	Parameter	Return
Channel Enabled	:10	2byte (hex)	(De)Activate
Integration Time	:23		1: Reset all RTC registers
Auto Integration	:26	Flag (boolean)	0: Constant Exposure Time 1: Auto Tuning
Next Lamp Delay	:27	Timespan (dec)	Pre-glowing time before a measure starts on this Channel
Spectrum Smoothing Factor	:50	Number (dec)	Matrix size of the smoothing algorithm
Spectrum Average Count	:52	Number (dec)	Amount of accumulate spectra
Temperature Averaging	:53	<Channel (dec)> Number (dec)	Amount of values for the Average Temperature
Temperature Offset	:75	Channel (dec), Offset (hex)	Delta to the existing offset
Analog Limits	:81		
Watchdog	:88	Flag (boolean)	1: Reset Watchdog Relay
Reboot	:C2	Flag (boolean)	1: Reboot

## Specific Data Types

## Relay Type Description

Position	Function	Description	
1. Bit	Activation Bit		
2 – 3. Bit	Module Index	0: Module 1 1: Module 2	2: Module 3 3: Module 4
4. Bit	New Group Bit	New Condition Group	
5 – 6. Bit	Condition Bit	0: Channel Condition 1 1: Module Watchdog	2: Device Watchdog 3: Not defined
7 – 8. Bit	Channel Index	0: Channel 1 1: Channel 2	2: Channel 3 3: Channel 4
9. Bit	On Error	Track Channel Error	
10 – 16. Bit	Unused		
17 – 32. Bit	Temperature Limit	16-bit Integer (tenths °C)	

## Technical data

## Specific Data Types

## Relay Type Description

Description	Specification
Housing material	Aluminum
Instrument number of channels	2 to 16
Fiber optic protection	PTFE sheath, PTFE spiral wrap
Temperature measuring range	-40 °C to 200 °C
Accuracy	< ±1 K
Resolution	0.1 K
Measuring time/channel	250 ms
Operating temperature	-20 °C to 70 °C
Light source lifetime	Life of transformer
EMI/RFI susceptibility	Immune
Operational environment humidity	Up to 95 % RH non-condensing
Display	Large 7" TFT display; allows for complete system configuration
LED	Three operation, health and alarms status LEDs
Data recording	Event log; temperatures recording; capacity sufficient for life of transformer
Communication protocols	Modbus RTU; Modbus TCP; DNP3*; IEC61850*; IEC60870-5-101*; IEC60870-5-104* (*Optional)
Analog outputs	Optional, one per channel; 4-20 mA DC or 0-10 V DC
Relays	Optional, four per measurement module; System health (= Watchdog) relay for each measurement module programmable; Relays are rated 5 A/240 V AC or 0.3 A/240 V DC or 8 A/24 V DCs and isolated
Power consumption	Maximum 40 W
Power supply	18-28 V DC; Can be supplied with power converter to match any requirement
Dimensions and mass	248.4 mm x 203.7 mm x 154.6 mm, 1.9 kg
Standards	Tested for: Vibration and shocks during operation and transportation; earthquake; humidity operation; temperature operation; ESD; radiated emissions; conducted emissions; electrical fast transient/burst; surge; radiated and conducted RF immunity; power frequency immunity; voltage dips and interruptions; damped oscillations; insulation; impulse. Test reports available upon request

# Terms and abbreviations

Term/abbreviation	Definition
Admin	Abbreviation for administrator used in the FOTEMP T30 software. The administrator can log in to the FOTEMP T30 software using a password. The administrator has access to all software screens and has the right to modify the settings.
Config	Abbreviation for configuration, used in the FOTEMP T30 software for the description of the relay and channel configuration screens.
CPU module	A module of the FOTEMP T30 device, which contains ethernet, central processing unit and USB interfaces.
CSV	CSV is a file format and stands for character-separated values. The measurement data is recorded in a log file in CSV file format. The CSV file is stored internally in the FOTEMP T30 device and can be downloaded via a USB interface.
DHCP	Dynamic Host Configuration Protocol is a network management protocol used to automate the process of configuring devices on IP networks.
DIN rail	A DIN rail is a metal rail of a standard type widely used for mounting circuit breakers and industrial control equipment inside equipment racks. It is possible to mount FOTEMP T30 using the DIN rail mounting points on the back panel of the device.
DNP3	Distributed Network Protocol 3 is a set of communications protocols.
Events	All actions, temperature alarms or changes in the settings that are recorded. Events are automatically recorded with a time interval of one minute.
Fiber optic connection	Describes the link between a fiber optic cable into the fiber optic connector socket of the FOTEMP T30.
Fiber optic connector	Term which describes both socket and cable plug. Together they build the fiber optic connection.
Fiber optic connector plug	Plug at the end of a fiber optic cable. It can be inserted into the fiber optic connector socket to build a fiber optic connection.
Fiber optic connector socket	Fiber optic socket installed on the FOTEMP T30 measurement module, where you can connect a sensor for temperature measurement.
IEC 60870-5	A general communication protocol definition developed by the International Electrotechnical Commission (IEC).
IEC 61850	An international standard defining communication protocols for intelligent electronic devices at electrical substations.
Log file	The recorded temperature measurement data and device- and configuration-change-events.
Measurement module	A module of the FOTEMP T30 device, which contains fiber optic connector sockets, relays and analog outputs. The FOTEMP T30 can be equipped with max. four measurement modules.
Modbus	A data communications protocol originally published by Modicon
NTP	Network Time Protocol (NTP) is a networking protocol for clock synchronization between computer systems.
Status LEDs	LEDs are situated on the front panel of the FOTEMP T30. They show the current status of the device and tell the user if the device is working properly or if there are any malfunctions.
Supply module	A module of the FOTEMP T30 device, which contains the power supply and serial ports.
Watchdog	The watchdog is a timer used to detect and recover from system malfunctions. During normal operation, the system regularly resets the watchdog timer. If, due to an error, the system fails to reset the watchdog, the timer will elapse and generate a timeout signal

**COMEM SpA**

Localita' Signolo 22, S.R. 11  
36054 Montebello Vicentino  
Vicenza - Italy  
Tel +39 0444 449 311

**COMEM Optocon GmbH**

Washingtonstraße 16/16a  
D-01139 Dresden  
Germany  
Tel +49 (0)351 8435990

This installation manual contains essential information for the user required to install & operate the product. In case you need any further information, contact us at [customerservice@it.comem.com](mailto:customerservice@it.comem.com)

**www.comem.com**

The data and illustrations are not binding. We reserve the right to modify the contents of this document without prior notice following the technical and product developments.

Copyright 2026 COMEM. All rights reserved

**Manual-03-2026**