

INSTRUCTION MANUAL

FOTEMP HD20



Content index

General	3
Safety	3
Unpacking, inspection, service	3
Product description	4
Calibration	4
Quick start	5
Installation.....	5
Automatic Integration Time Adjustment	6
Sensor connection.....	6
Sensor handling.....	7
Sensor/connector cleaning	8
User interface	8
Reference sensor.....	9
Logging.....	9
Serial communication.....	10
Troubleshooting	10

General

The fiber optic thermometer described in this instruction manual has been designed and manufactured using state-of-the-art technology.

All components undergo strict quality and environmental criteria during production. This manual contains important information on how to handle the device.

Follow all safety and work instructions to ensure safe use. Please adhere also to the relevant local accident prevention and general safety regulations for the device's range of use.

The operating instructions are an essential part of the product and should be kept near the device and readily accessible to trained personnel at all times. Qualified personnel must carefully read and understand the operating instructions before using the device.

The manufacturer's liability is void if the device is mis-used, operating instructions are not followed, unqualified personnel are assigned, or unauthorized modifications are made.

General terms and conditions contained apply. Subject to technical changes.

Safety

Safety instructions

This manual contains important information to ensure personal safety and to prevent damage. Safety instructions in this manual are shown in three different forms to emphasize important information.

	WARNING
Indicates a potentially dangerous situation that can result in equipment damage, injury or death if not avoided.	

	CAUTION
Indicates a potentially dangerous situation that can result in minor injuries or damage to equipment or the environment if not avoided.	

	NOTE
Points out useful tips, recommendations, and information for efficient and trouble-free operation.	

Skilled personnel:

Only qualified personnel should commission and operate the devices.

Skilled personnel are those with technical training, knowledge of measurement and control technology, and experience and knowledge of country-specific regulations, current standards, and directives.

Intended use:

The device has been designed and built solely for the described intended use and must only be used accordingly. The technical specifications contained in this manual must be observed.

Unpacking, inspection, service

Please make sure to follow these instructions when unpacking and inspecting your system components:

1. Check all materials against the enclosed packing list.
2. Carefully unpack and inspect all components for visible damage.
3. Save all packing materials, until you have inspected all components and find that there is no obvious or hidden damage.
4. If you notice any damage upon unpacking, contact us immediately.
5. In case of a malfunction or service request, please contact us.

Technical support

Email: customerservice@it.comem.com
 TD +49 351 843 599 0

Equipment return address

COMEM Optocon GmbH
 Washingtonstrasse 16/16a
 01139 Dresden, Germany

Disposal

Inoperable devices must be disposed of in compliance with local regulations for electronic materials.

Product description

The FOTEMP HD20 is a portable fiber optic thermometer used for measuring temperature in an environment with high electromagnetic interference or high-power microwave fields. It can also be used in places where using an electric temperature probe is not feasible.

This device allows for comfortable and safe temperature measurements, even in challenging situations, with an impressive system accuracy of $\pm 0.2^\circ\text{C}$. Additionally, the included software enables comprehensive monitoring of the results.

FOTEMP HD20 is a compact, user-friendly, and easy to operate device suitable for various applications, including:

- EMI, RFI, and microwave environments
- High voltage environments
- Harsh and hazardous environments
- Nuclear environments
- Process monitoring
- MRI and other magnetic field applications.

The probes used for temperature measurement consist of a PTFE-housed glass fiber with a GaAs crystal (gallium arsenide) at the tip, the probe is completely non-metallic and therefore completely non-conductive.

COMEM's fiber optic sensors offer complete immunity to RF and microwave radiation with high temperature operating capability, intrinsic safety, and non-invasive use. The probes are also designed to withstand harsh and corrosive environments.

Starting at a light wavelength of 850nm GaAs becomes optical translucent. Since the position of the band gap is temperature dependent, it shifts about 0.4nm/Kelvin. The measurement device contains a light source and a device for the spectral detection of the band gap. This guarantees fast, repeatable, and reproducible measurements.

Thanks to its accompanying software FOTEMP Assistant 2, measurement results can be easily controlled and monitored. Over the entire life of the system re-calibration is not required to remain within the specifications.

Inoperable instruments must be disposed of in compliance with local regulations for electronic materials.

Measurement	
Measurement Range	-200 °C to 300 °C
Measuring Time	< 250 ms per Channel
Accuracy (Standard Deviation)	0.2 K
Resolution	0.1 K
Probes	Compatible with all COMEM fiber optic temperature probes

Environment	
Communication Protocols	ASCII
Interfaces	USB
Operating Temperature	-20 °C to 60 °C
Storage Temperature	-20 °C to 70 °C
Connector Type	ST

Device	
Channel	1, 2
Display	3,5" uLCD
Additional Interfaces	Reference sensor possible (DS18Z20U)
Data Logging	Continuous or timed temperature logging and spectrum snapshots
Power Supply	9 VDC / 1 A or USB
Dimension	120 x 112 x 40 mm
Weight	0,6 kg

Calibration

For accurate temperature measurements in critical areas, we provide a comprehensive calibration service for our fiber optic temperature measurement devices. Our modern labs and our qualified staff ensure very accurate and fast calibration.

You will receive your unit back within a few days, ready to start your fiber optic measurement projects. Your fiber optic thermometer comes factory-calibrated. An annual re-calibration is not necessary, unless required by internal company regulations. All calibrations are performed at our factory.

We provide a full certificate of test results for each calibrated device.

For more information contact us:
customerservice@it.comem.com

Quick start

This quick reference guide provides an overview for quick usage. However, it can not replace comprehensive literature containing important information and safety warnings.

Front panel

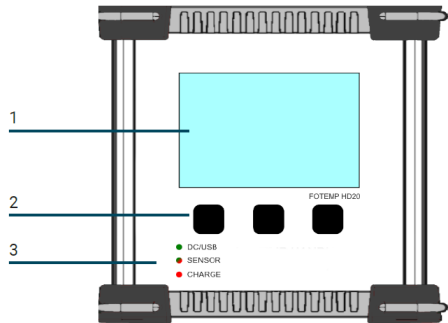

1. Display
The LCD displays the temperature readings, time, date, charge state, and other user information.
2. Buttons
Three buttons are available to control the device
3. Status LED's
The Sensor LED indicates the status of each channel. If the sensor is damaged, defective, or nonexistent, the LED flashes red. During normal operation, when the sensor is available and measurements are being carried out, it flashes green.

Top panel

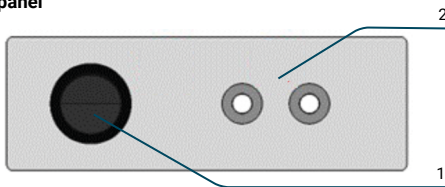

1. Power switch
2. Sensor connectors
These are ST-type connectors that are compatible with the optical temperature sensors. If you need to extend the fiber optic temperature sensor, please use the extension cables from COMEM. For thermometers that have only 1 or two channels, only 1 or 2 sensor connectors are used.

Back panel

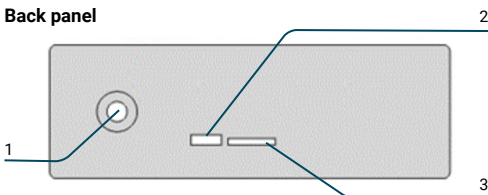

1. Power supply
Please use only the provided power supply
2. USB interface
3. Micro SD-Card slot.

Installation

1. Connect the provided optical fiber temperature sensors to the ST socket located at the top of the device, where the ON/OFF switch is located.
2. If you need to power the thermometer, please use the provided power supply.
3. Once the device is powered on, a loading screen will appear.
4. When the device is ready, temperature values for the different channels will be displayed.
5. The thermometer is now ready for measurement.
If a sensor is not connected or the signal quality is poor, the display will show „ERR“.



CAUTION

**FOTEMP HD20 is only compatible with COMEM optocon fiber optic sensors.
Do not use temperature sensors from other brands.**

General installation guidelines:

When installing the fiber optic device, carefully follow the installation instructions, paying close attention to the order of the instructions.

Sensor connection (Page 6)

The temperature sensors are connected to the ST socket using ST plugs. When inserting the plugs, apply slight pressure against the spring and turn them clockwise. All COMEM fiber optic temperature sensors can be connected.

Sensor handling (Page 7)

The sensor comprises an ST plug at one end and a gallium arsenide crystal at the tip. The crystal is sensitive and should not be subjected to excessive mechanical stress. Please refer to the information regarding the bending radius of the sensor. Forcefully bending the sensor can lead to fiber breakage, resulting in damage that will require repair or replacement.

Serial communication (Page 10)

The device can be connected to a PC via USB port located at the bottom of the device.

Automatic Integration Time Adjustment

Due to factors such as excessive bending/looping of the fiber or mechanical damage, the light signal received by the measuring device may be reduced (below 50%), which is usually a limiting factor for measuring devices. However, to ensure accurate measurements even with high attenuation, FOTEMP devices are equipped with a special function that automatically maintains a high signal strength.

With the "Automatic Integration Time Adjustment" function, highly attenuated signals can be optimized and maintained within a range of 35% to 100% and continue to be used for temperature measurement. Signal levels can be monitored via the FOTEMP Assistant software or, for devices with an integrated display, are shown directly on the user interface.

If the signal strength falls below 35%, an error is displayed in the FOTEMP Assistant software or on the device display (if available). In this case, the sensor or device must be checked for troubleshooting. Please refer to document AN206_FOTEMP_Device_Troubleshooting for more information.

Sensor connection

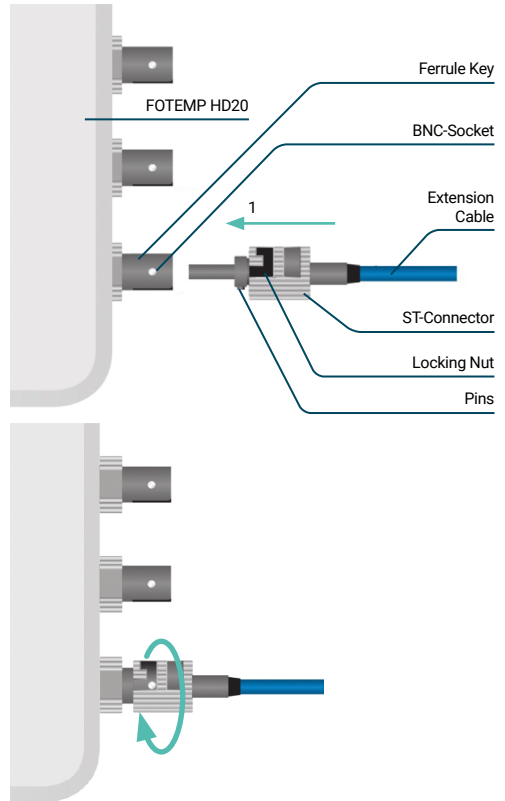

For accurate measurements and to ensure the long life of fiber optic sensors and instruments, it is necessary to clean them regularly. More information about cleaning can be found on page 8.

	NOTE
Any unused channels must be protected with supplied dust caps.	

Test of sensor functionality

To test the functionality of the sensor, you can place the sensor into a test liquid with a known temperature (e.g. boiling water). The sensor will respond to the temperature within a few seconds.

Sensor handling

Bending radius:

Fibers with a core diameter of $200\mu\text{m}$ have a short time ($\leq 10\text{min}$) bending radius of $10,0\text{mm}$ and a long time ($>10\text{min}$) bending radius of $27,0\text{mm}$.

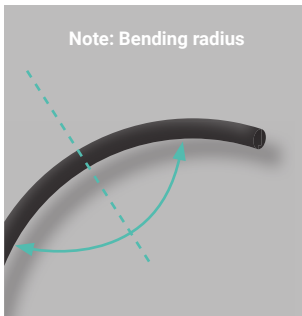
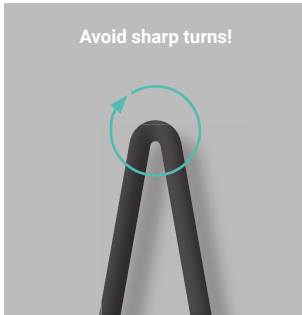

Mechanical load:

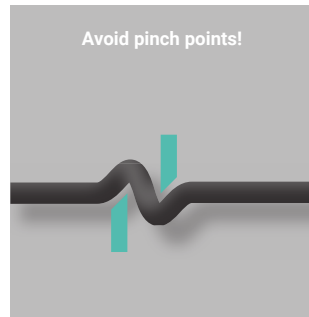
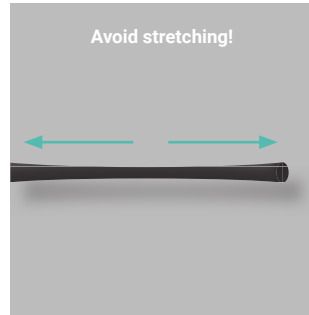

Storage:

When not in use, the sensor should be carefully stored in its delivery box or suitable storage container to prevent bending or crushing.

Sensor/connector cleaning



Instructions

Clean the ST sensor's connector with the connector cleaner. Softly press the connector on the cloth tape and rotate across the tape while rotating the connector. You can clean up to 6 connectors before advancing the tape. Tear off excess tape as required.

Take a swab and wet it with the isopropanol wipes. Insert the swab into the internal connector of the conditioner by rotating it smoothly. Avoid using cotton swabs.

User interface

The FOTEMP HD20 has a large display that shows temperatures, spectra, and menu options across 5 different pages. The buttons, each with a designated function displayed in the footer, are used for control.

Main page

You can see the average temperature of each channel.

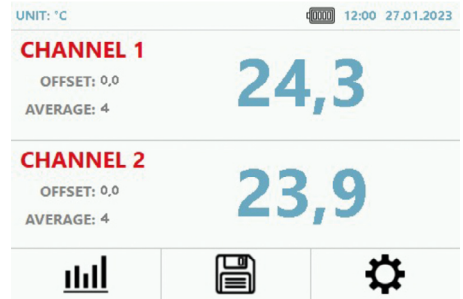

Spectrum: Switches to the spectrums page.

Save: Start/Stop the logging function.

Settings: Switches to the channel menu page.

Spectrum page

You can see the spectrum of the selected channel.

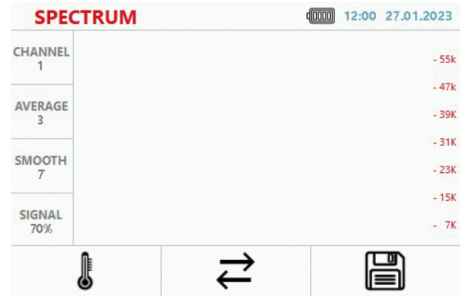



Temperature: Switches to the temperature page.

Switch: Change the shown channel.

Save: Write a snapshot of the spectrum on the sd card.

Channel menu page

You can see the channel related setting.

SETTINGS 12:00 27.01.2023		
CHANNEL	DEVICE	INFO
NUMBER	2	
OFFSET	0,0	
T. AVERAGE	4	
  		



 Temperature: Switches to the temperature page.

 Switch: Step to the next entry.

 Switch: Edit the selected entry.

Device menu page

You can see the device related settings.

SETTINGS 12:00 27.01.2023		
CHANNEL	DEVICE	INFO
S. AVERAGE	3	
SMOOTHING	7	
LOGINTERVAL	10 sec	
TIME	27 . 01 . 23 12 : 00 : 00	
  		



 Temperature: Switches to the temperature page.

 Switch: Step to the next entry.

 Switch: Edit the selected entry.

Info menu page

You can see the general information.

SETTINGS 12:00 27.01.2023	
CHANNEL	INFO
SERIAL	12345
FIRMWARE	4.000
LIBRARY	1.500
 	

 Temperature: Switches to the temperature page.

 Switch: Edit the selected entry.

Reference sensor

One equipment variant provides the option to connect a reference sensor, which can act as a control sensor and be displayed on the screen.



 **CAUTION**

This function only supports the DB18S20Z 1-Wire sensor.
Please do not use other sensors.

Logging

Temperature logging

The device can store the temperature at set time intervals or continuously after each measurement. The recorded values are stored in a CSV file on the SD card.



You can adjust the time interval in the device menu from 0 (continuous) to 10 seconds.

LOGINTERVAL	10 sec
-------------	--------

The device stores spectra on the SD card as individual snapshots in a CSV file. To save the spectra again, you need to initiate the process once more.



Serial communication

You can connect the device to your computer using a USB-C cable. Once connected, you can use our free software FOTEMP Assistant 2, to view temperatures on your computer, customize settings, log temperatures, and display them in charts.

Alternatively, you can communicate with the device using our open ASCII protocol or Modbus.

Troubleshooting

For more information please contact us or consult the Application note AN206: FOTEMP Device Troubleshooting <https://comem.com/en/library/>.

COMEM SpA

Localita' Signolo 22, S.R. 11
36054 Montebello Vicentino
Vicenza - Italy
Tel +39 0444 449 311

COMEM Optocon GmbH

Washingtonstraße 16/16a
D-01139 Dresden
Germany
Tel +49 (0)351 8435990

This installation manual contains essential information for the user required to install & operate the product. In case you need any further information, contact us at customerservice@it.comem.com

www.comem.com

The data and illustrations are not binding. We reserve the right to modify the contents of this document without prior notice following the technical and product developments.

Copyright 2026 COMEM. All rights reserved

Manual-02-2026