

TECHNICAL GUIDE

## Buchholz relays





# Content index

Application .....	4
Technical data .....	5
Dimensions.....	7
Order sheet.....	12

# Application

Standard features												Options											
Type	Pipe nominal diameter	L (mm)	Holes x Ø (mm)	Wheelbase (mm)	Discharge valve	Pneumatic valve	Max n° of contacts	Alarm contact test available from ground level	Corrosion protection: C4 Moderate salinity (ISO 12944)	Gas accumulation for alarm (ml)	Vibration class 4M4 (Speed up to 1,5 m/s)	Vibration class 4M6	Damper held (manual reset for flow flap)	OLTC Application	Railway application	Alarm - Trip contacts test available from ground level	Double flow flaps (alarm and trip signal)	4-20 mA for gas accumulation monitoring	MODBUS RTU communication	Corrosion protection: C5-M coastal area (ISO 12944)	Corrosion protection: CX Off Shore (ISO 12944)	GSD application	
BG	25	185	G1 1/2	-	●	●	4	●	●	100-230	●	●	-	-	-	-	-	-	-	●	-	●	
BR	25	200	n°4xØ14	Ø85	●	●	6	●	●	100-230	●	●	●	-	●	-	-	-	-	●	●	●	
	50	195	n°4xØ18	Ø125	●	●	6	●	●	200-300	●	●	●	-	-	-	-	-	-	●	●	●	
	80	195	n°4xØ18	Ø160	●	●	6	●	●	200-300	●	●	●	-	-	-	-	-	-	●	●	●	
	80	195	n°8xØ18	Ø160	●	●	6	●	●	200-300	●	●	●	-	-	-	-	-	-	●	-	●	
eBR	80	195	n°4xØ18	Ø160	●	●	4	●	●	200-300	-	●	●	-	-	-	●	●	●	●	●	●	●
	80	195	n°8xØ18	Ø160	●	●	4	●	●	200-300	-	●	●	-	-	-	●	●	●	●	●	-	●
BS	25	127	n°4xM10	Ø72	●	●	4	●	●	100-230	●	●	-	-	-	●	-	-	-	●	-	●	
	50	185	n°6xØ11	Ø110	●	●	4	●	●	200-300	●	●	-	-	-	●	-	-	-	●	-	●	
	80	185	n°6xØ11	Ø130	●	●	4	●	●	200-300	●	●	-	-	-	●	-	-	-	●	-	●	
NF	25	240	n°4xØ11	Ø85	●	●	4	●	●	100-230	●	●	-	-	-	-	-	-	-	●	-	●	
	50	240	n°4xØ18	Ø125	●	●	4	●	●	100-230	●	●	-	-	-	-	-	-	-	●	-	●	
	80	240	n°4xØ18	Ø160	●	●	4	●	●	100-230	●	●	-	-	-	-	-	-	-	●	-	●	
C1	25	160	n°4xØ12	Ø75	●	●	4	●	●	100-230	●	●	-	-	-	-	-	-	-	●	-	●	
OR	25	200	n°4xØ14	Ø85	●	●	3	●	●	-	-	●	●	●	-	-	-	-	-	●	-	●	

Triggering oil flow speed values

Type	Diameter mm	Vibration class 4M4 m/s	Vibration class 4M6 m/s
BG C1	25	1.0	1.0
	25	1.0	1.0, 1.5, 2.0, 2.5
BR	50	1.0, 1.5	1.0, 1.5, 2.0, 2.5
	80	1.0, 1.5	1.0, 1.5, 2.0, 2.5, 3.0
eBR	80	NA	1.0, 1.5, 2.0, 2.5
BS NF	25	1.0	1.0
	50	1.0, 1.5	1.0, 1.5, 2.0, 2.5
	80	1.0, 1.5	1.0, 1.5, 2.0, 2.5
OR	25	na	1.0, 1.5, 2.0, 2.5, 3.0

# Technical data

Buchholz Relay	Technical data
<b>Material</b>	
Housing and upper part inclusive terminal box	Aluminum casting, RAL 7032, powder coated; Coastal area model on request (surface treatment, not painted) Off Shore model on request (Surface treatment, RAL 7035; only for some models see page 4)
<b>Characteristics Data</b>	
Standard	IEC 60076-22-1
Installation	Indoors and outdoors, tropical proof
Ambient temperature	-40°C to 80°C / -40°F to 176°F
Oil temperature	-40°C to 120 °C / -40°F to 248 °F (artic version on demand)
Degree of protection	IP65 in accordance with EN60529 (on demand IP66)
Rated insulation voltage	2.5 kV AC 1 min between contact and earth
Nominal tube diameter	DN25, DN50 and DN80 or G1 ½" threaded connection
Flap triggering oil flow	1.0 m/s to 3.0 m/s (each ±15%)
<b>Protected Reed Switch</b>	
Number and types	Normally closed (NC), normally open (NO) and/or change over contacts (CO) on customer requests; potential free; 3 switches per function and max 6 switches
Nominal Voltage	24 – 230 VAC/DC
Max nominal current	2A
Min switching current	10 mA/24 VDC
Max breaking capacity DC	250W (L/R<40 ms)
Max breaking capacity AC	400 VA (cosφ>0.5)
Rated insulation voltage	2.5 kV AC 1 min between contacts and earth, 1.0 kV AC 1 min between open contacts
Insulation resistance	1000 MΩ/500 VDC
<b>Connection</b>	
Connection terminals	Min 0.25 mm <sup>2</sup> / max. 4 mm <sup>2</sup>
Cable Gland	For type OR25 N°1 x M20 x 1.5; for types NF and eBR N 2° M25 x 1.5; for all other types N 1° M25 x 1.5
<b>Mechanical test</b>	
Sinusoidal (EN 60721-3-4)	cl.4M4: 2-9 Hz (6 mm peak to peak), 9 – 200 Hz (1 g) – All axis cl.4M6: 2-9 Hz (14 mm peak to peak), 9 – 200 Hz (2 g) – All axis
Shock	cl.4M4: 10 g (11 ms) in all the directions (EN60721-3-4) cl.4M6: 20g vertical axis (Spectrum I in agreement with EN 60721-3-4)
Seismic	EN60068-3-3 (cl.0, level II)

# Dimensions

BR, NF and C1

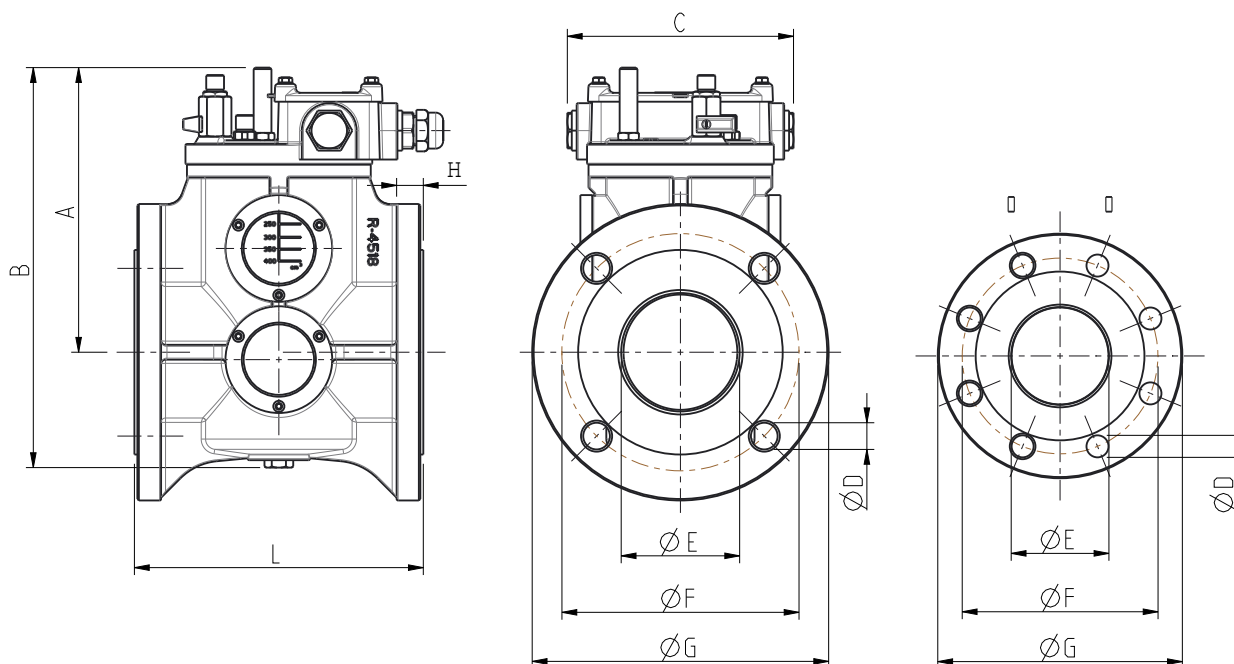

Type	ØE (mm)	L (mm)	A (mm)	B (mm)	C (mm)	ØF (mm)	G (mm)	ØD (mm)	N° holes	H (mm)
BR	25	200	160	215	152	85	Ø115	14	4	17
	50	195	178	254	152	125	Ø165	18	4	18
	80	195	193	270	152	160	Ø200	18	4	18
	80	195	193	270	152	160	Ø200	18	8	18
BR 6 switches	25	200	192	235	182	85	Ø115	14	4	17
	50	195	185	260	182	125	Ø165	18	4	18
	80	195	203	280	182	160	Ø200	18	4	18
	80	195	203	280	182	160	Ø200	18	8	18
NF	25	240	160	218	218	85	Ø115	11	4	15
	50	240	172	248	218	125	Ø165	18	4	15
	80	240	172	248	218	160	Ø200	18	4	15
C1	25	160	160	218	140	75	Ø100	12	4	10

# Dimensions

## BG25

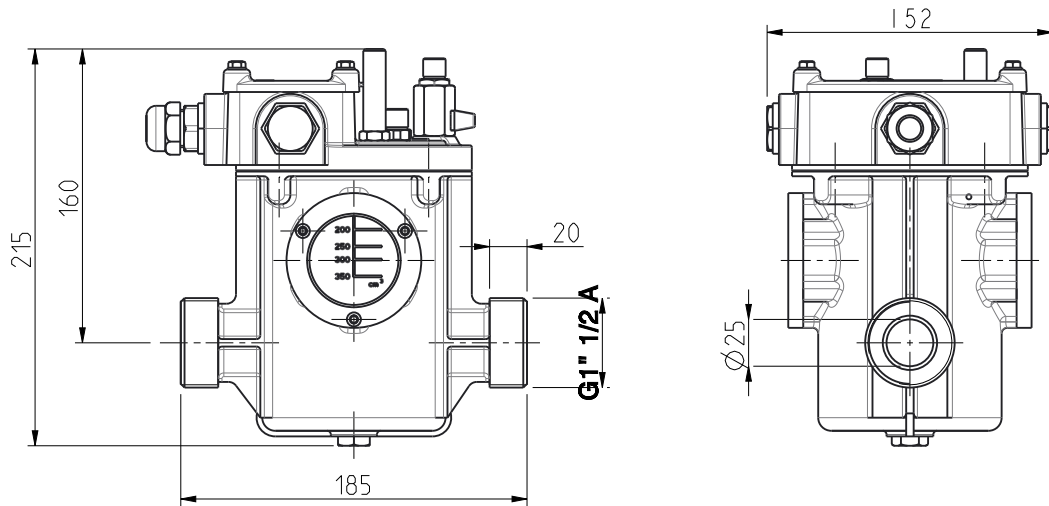

## OR25 (for OLTC application)

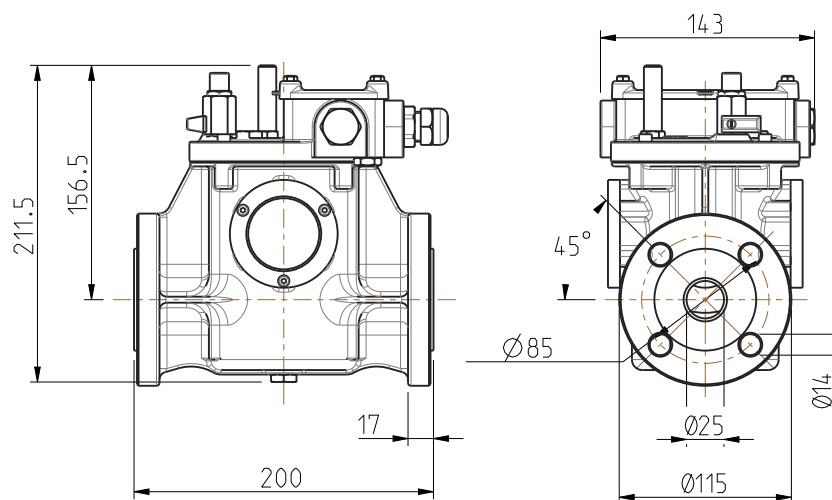

# Dimensions

BS25

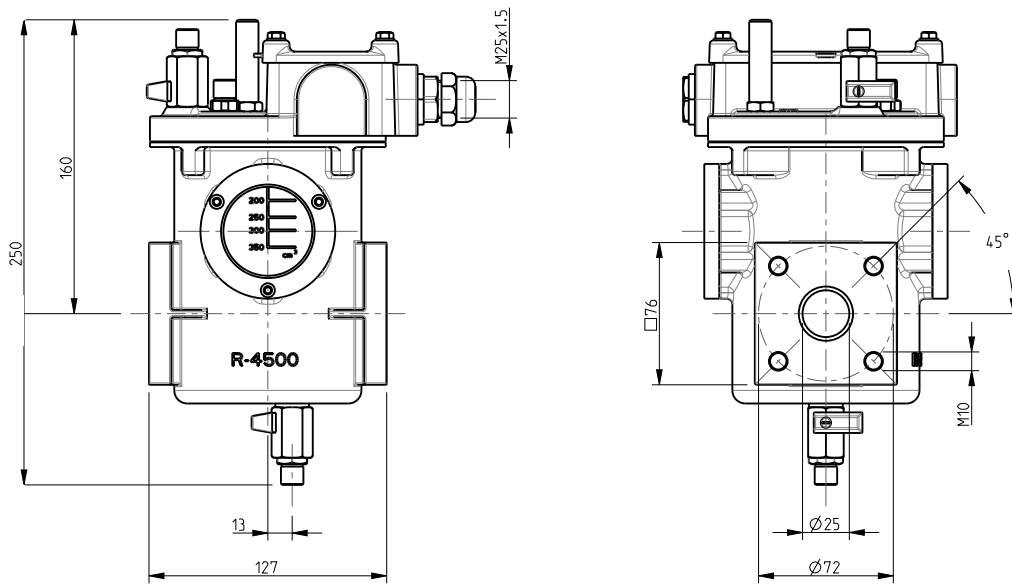

# Dimensions

## BS50 and BS80

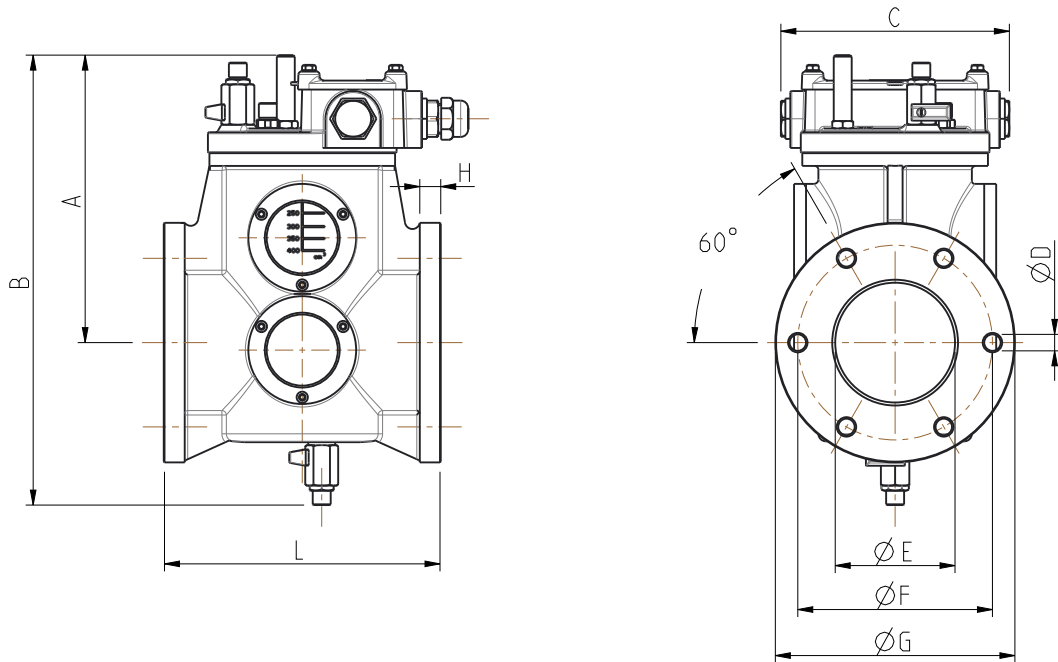

Type	ØE (mm)	L (mm)	A (mm)	B (mm)	C (mm)	ØF (mm)	G (mm)	ØD (mm)	N° holes	H (mm)
BS	50	185	178	288	144	110	Ø140	11	6	14
	80	185	178	288	144	130	Ø160	11	6	14

## GSD2: Gas sampling device\*

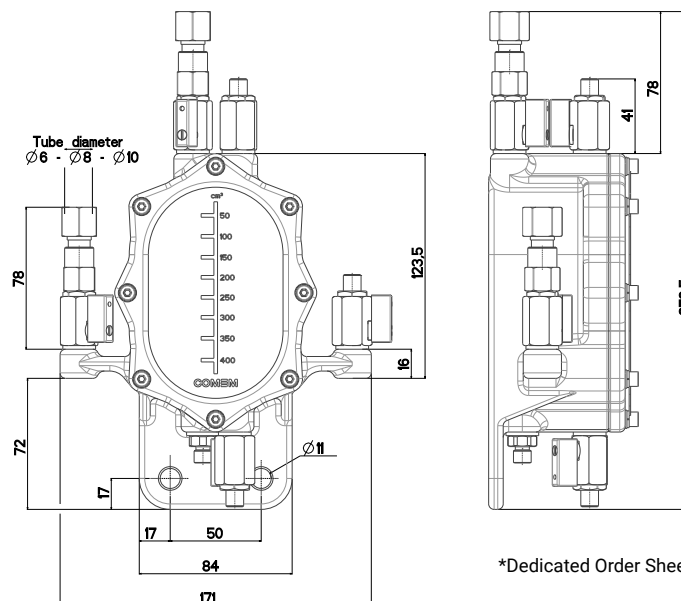

\*Dedicated Order Sheet for GSD2

# Dimensions

## eBR80 with analog and digital outputs

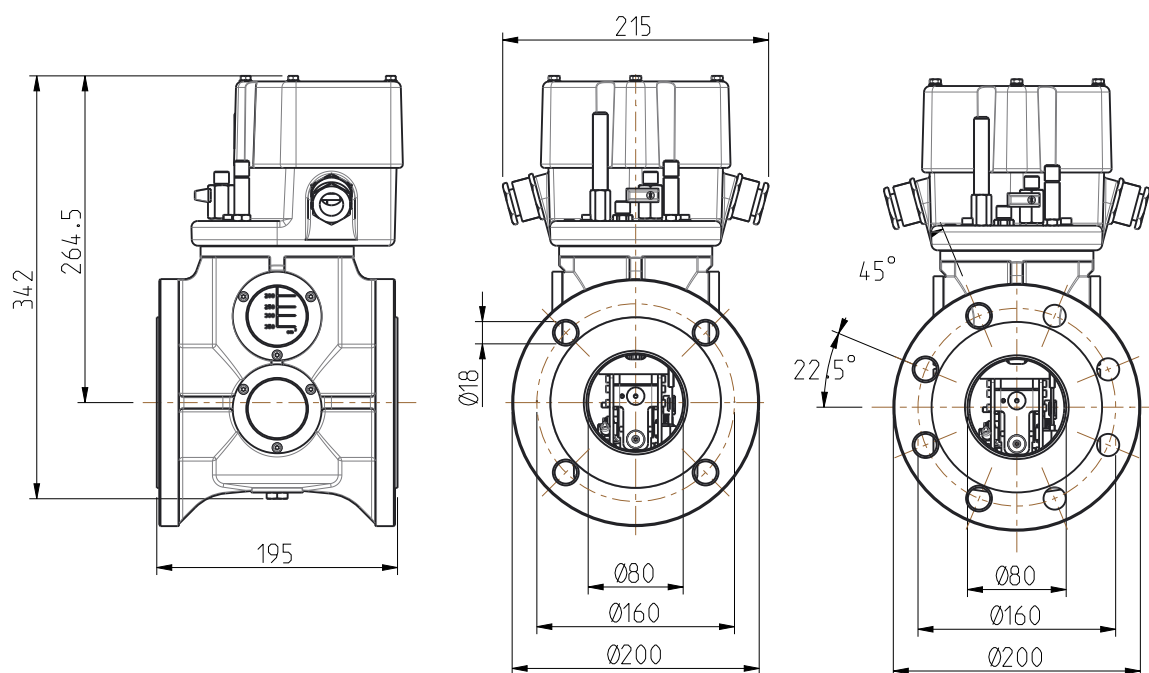

eBR	Technical data
Ventilation valve	To prevent the formation of condensation
Wires	Max 2.5mm <sup>2</sup> – advised 4x1mm <sup>2</sup> or 6x1mm <sup>2</sup> shielded twisted pair cable for analog/digital output
Rated voltage	24 VDC ±10% polarized
Current consumption	Max 0.5 W
Analog output (gas accumulation)	4-20 mA (dielectric strength between electronic board and analog output:1kV) Minimum / Maximum resistance: 100 / 470 Ω
Max distance for analogical output	Max 30 m / 98 ft (For different demands contact us: <a href="mailto:customerservice@it.comem.com">customerservice@it.comem.com</a> )
Digital output (optional)	Serial RS485 for MODBUS RTU (For different demands contact us: <a href="mailto:customerservice@it.comem.com">customerservice@it.comem.com</a> )
Distance for digital output	Max 30 m / 98 ft (For different demands contact us: <a href="mailto:customerservice@it.comem.com">customerservice@it.comem.com</a> )

For further information or clarification, please contact our support team:  
E-mail address: [customerservice@it.comem.com](mailto:customerservice@it.comem.com)

# Order sheet

Date	
Rev.	
Customer reference	

**Type**

eBR (4-20 mA and Modbus RTU)
BR
BG
BS
NF
OR (Ø25) - OLTC application
C1

**Pipe diameter (mm) (see table on page 4)**

Ø25
Ø50
Ø80
Ø80 – 8 holes flange (only for body type BR)

**Vibration class**

4M4 (standard, not available for CX corrosion protection)
4M6

**Damper held (only for metallic frame)**

YES
NO (standard)

**Triggering oil flow flap<sup>(2)</sup> (see table page on page 4)**

1.0 m/s
1.5 m/s
2.0 m/s
2.5 m/s
3.0 m/s

**Gasket material**

NBR (from -40°C upto +120°C) Standard
HNBR (From - 40°C upto +140°C)
Viton (from -10°C upto +150°C)
Fluorosilicone (from -60°C upto +200°C)

**Corrosion protection**

C4 Medium acc. to ISO 12944 (standard)
C5 Medium acc. to ISO 12944 (not paintable)
CX acc.to ISO 12944 (RAL 7035, only specific models - see page 4)

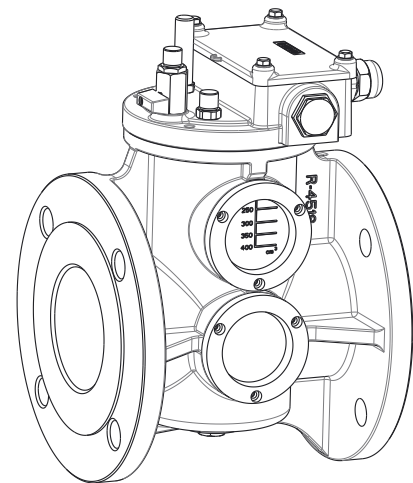

**Wiring diagram<sup>(1)</sup>**

Type	Alarm contacts	Trip contacts
A	1 x NO	1 x NO
L	1 x CO	1 x CO
G	1 x NO	2 x NO
P	2 x NO	1 x NO
I	2 x NO	2 x NO
V	2 x NC	2 x NC
S1 (for BR type only)	1 x NO	3 x NO
S2 (for BR type only)	2x NO	3 x NO
S3 (for BR type only)	3 x NO	3 x NO

**OR25 for OLTC application (Ø25)**

**Wiring diagram<sup>(1)</sup>**

Type	Trip contacts
GO	2 x NO
RO	1 x NC + 1 x NO
CO	2 x CO
TO	1 x CO + 1 x NO

Legend:  
**NO:** Normally Open  
**NC:** Normally Close  
**CO:** Change Over

Notes:  
 (1) Buchholz with analog and digital output: see the dedicated section on page 12

# Order sheet

Date	
Rev.	
Customer reference	

## eBR with analog and digital outputs

### Wiring diagram

Type	Alarm gas	Alarm speed	Trip
F	NO	NO	NO
N	NO	NO	2 x NO*
R	NC	NO	NC
Z	CO	NO	CO

\* 2 independent switches

### Alarm triggering oil flow flap

-
1.0 m/s
1.5 m/s
2.0 m/s

### Trip triggering oil flow flap\*\*

1.0 m/s
1.5 m/s
2.0 m/s
2.5 m/s

\*\* Values at least 0.5 m/s higher than alarm settings

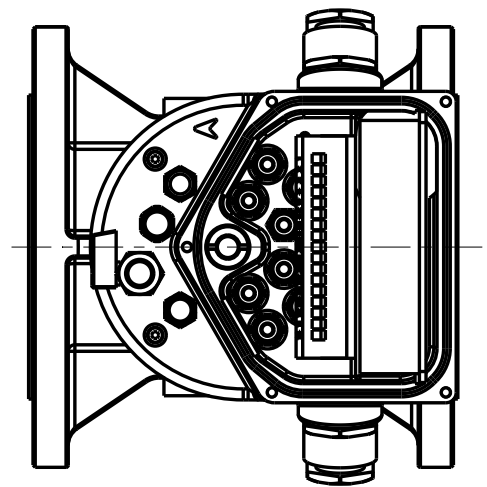

Electrical box

**COMEM SpA**

Localita' Signolo 22, S.R.11  
36054 Montebello Vicentino  
Vicenza - Italy  
Tel +39 0444 449 311

**[www.comem.com](http://www.comem.com)**

The data and illustrations are not binding. We reserve the right to modify the contents of this document without prior notice following the technical and product developments.

Copyright 2025 COMEM. All rights reserved

**Technical guide-05-2025**